

TUBE•LINE™

Tubeline Manufacturing Limited
6455 Reid Woods Drive RR #4
Elmira, Ontario, Canada N3B 2Z3

Email: sales@tubeline.ca

Fax: 519.669.5808

Tel: 519.669.9488

Toll-free (North America): 1.888.856.6613

www.tubeline.ca

Operator's Manual

Keep this manual with the machine at all times.

TL1000R

Balewrapper

TL1000R

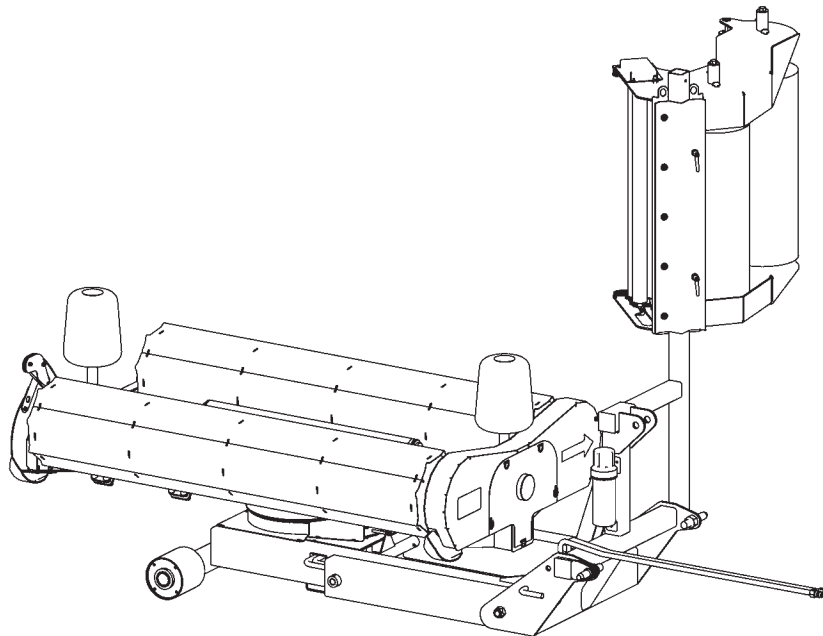

Operator's Manual

Thank you for choosing the Tubeline TL1000R Individual Bale Wrapper. Our hope is that it will give you many years of productive service. This machine is designed to wrap round bales in a film of plastic. The latest manual version can be found at www.tubeline.ca/support.php.

NOTE: Please read and understand this manual and the machine before operation.

Warranty and Limitation of Liability

All equipment is sold subject to mutual agreement that it is warranted by the company to be free from defects of materials and workmanship. But the company shall not be liable for special, indirect or consequential, damages of any kind under this contract or otherwise. The company's liability shall be limited exclusively to replacing or repairing without charge, at its factory or elsewhere, at its discretion.

Any material, or workmanship defects which become apparent within one year from the date on which the equipment was purchased, and the company shall have no liability for damages of any kind. The buyer by the acceptance of the equipment will assume all liability for any damages, which may result from the use or misuse by his employees or others.

Warranty coverage is null and void unless Warranty Registration form has been completely filled in and is on file at Tube-Line Manufacturing Ltd.

Serial Number Plate

The implement serial number is located on the front of the frame. This number helps us to track changes and improvements and must be mentioned when ordering parts or requesting service. For your convenience, a space has been provided inside the front cover of this manual to record the serial number, model number, purchase date, and dealer name.

Model No: _____ TL1000R

Serial No: _____

Date Purchased: _____

Dealer Name: _____

Dealer Contact: _____

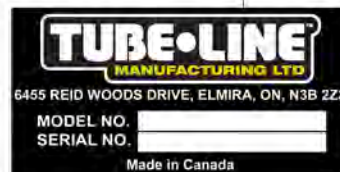
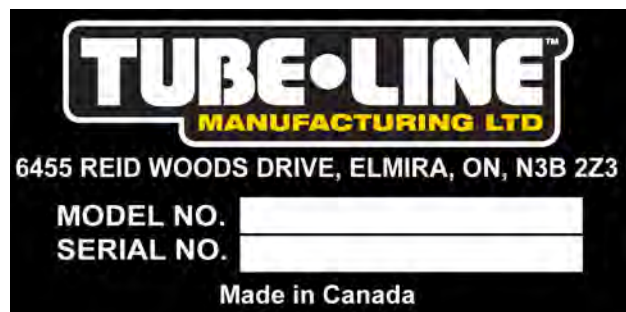
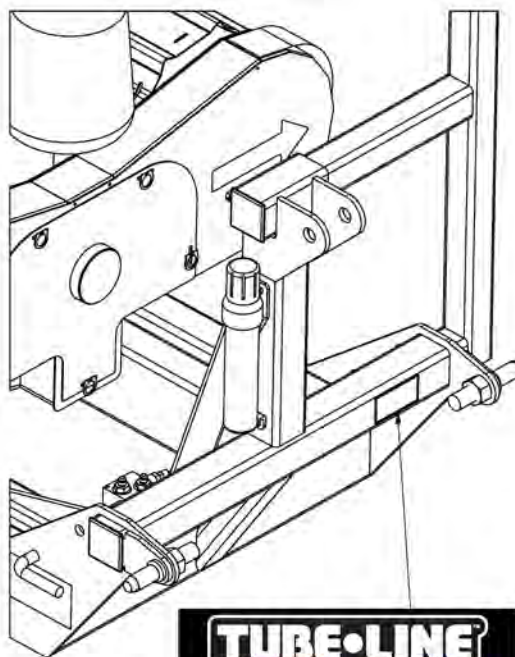

Table of Contents

Operator's Manual	II
Warranty and Limitation of Liability	II
Serial Number Plate	II
Section 1: General Information	1-1
Dimensions	1-1
Orientation	1-2
Terminology	1-2
Specifications	1-3
Suitable Wrapping Timeframe	1-3
Bale Sizes	1-3
Section 2: Safety	2-1
Safety Guidelines	2-1
Before Operation	2-1
Storage & Maintenance	2-1
Decal Locations	2-2
Safety Decals	2-4
Section 3: Initial Setup	3-1
Electrical Connection	3-3
Section 4: Adjustments and Repairs	4-1
Miter Gear Replacement	4-1
Tensioner Adjustment	4-1
Guide Roller Adjustment	4-2
Roller Chain Adjustment	4-2
Section 5: Operating Procedure	5-1
Tractor Hookup	5-1
Wrap Operation Setup	5-1
To Install Plastic Wrap Film	5-2
Trouble Shooting Plastic Installation	5-3
Plastic Wrap Requirements	5-4
Loading Bales	5-4
First Bale Wrapping	5-5
Unloading	5-5
Continuous Wrapping	5-6
Transportation	5-6

Section 6: Bale Wrap Computer (BWC)	6-1
BWC - Introduction	6-1
BWC - Control Switches	6-1
BWC - Channel 1 - Current/Target Wraps Display	6-2
BWC - Manually reset Current No. of Wraps to Zero	6-2
BWC - Program the Target Wraps.	6-2
BWC - Early Warning Alarm	6-3
BWC - Channel 2 - Store Totals	6-3
BWC - Display a Store Total.	6-3
BWC - Select a Store Total	6-4
BWC - Reset a Store Total	6-4
BWC - Channel 3 – Part Total	6-4
BWC - Display Part Total.	6-4
BWC - Reset Part Total	6-4
BWC - Channel 4 - Grand Total.	6-5
BWC - Display Grand Total	6-5
BWC - Channel 5 - Bale Wrapping Rate	6-5
BWC - Display Bale Wrapping Rate	6-5
BWC - Reset Timing Period.	6-5
BWC - Channel 6 - Bale Wrapping Speed	6-5
BWC - Display Bale Wrapping Speed	6-5
BWC - Program the Overspeed Alarm	6-6
BWC - Total Reset.	6-6
Section 7: Grease Points	7-1
Grease Gun	7-1
Aerosol Grease	7-2
Torque Values - Imperial	IV
Torque Values - Metric	V

Section 1: General Information

Dimensions

Side

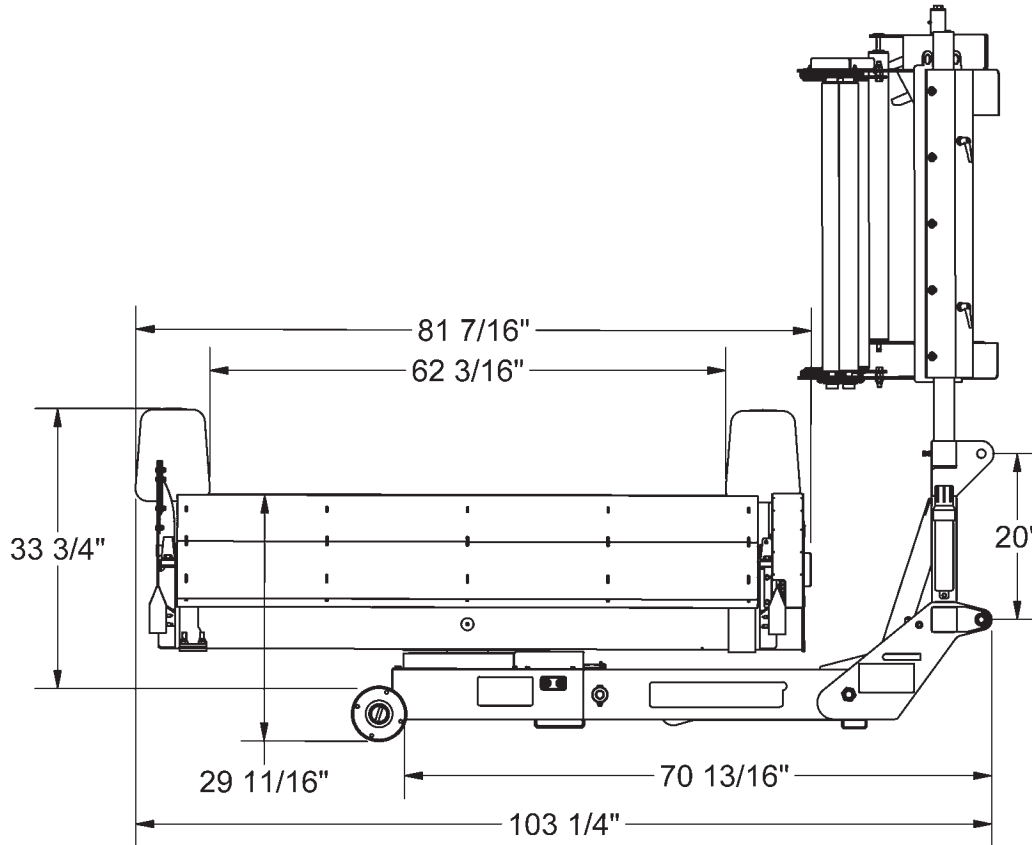

Front

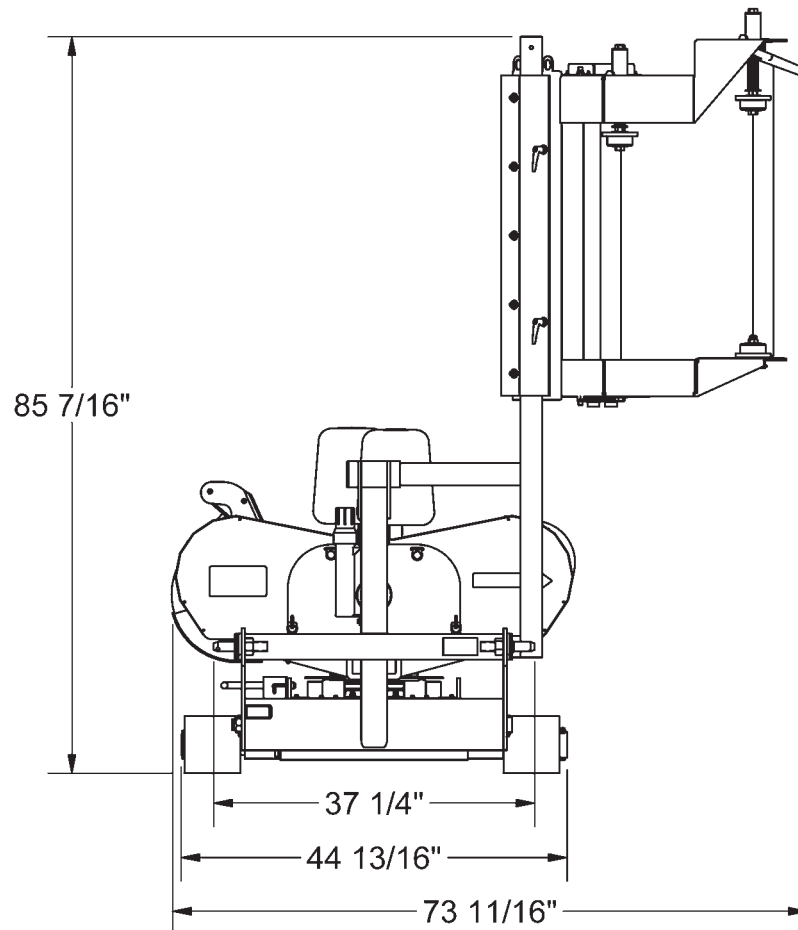

Orientation

Directional references in this manual are dependant on the operator's position from a forward pointed position with this machine hitched.

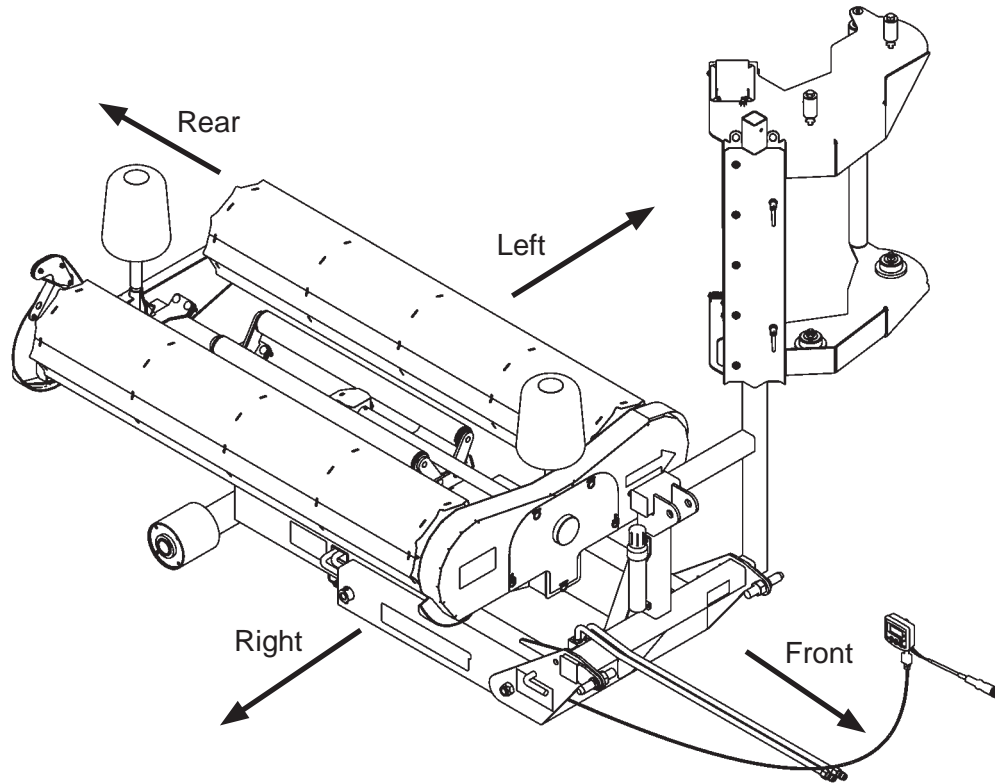

Terminology

Common terms used in this manual.

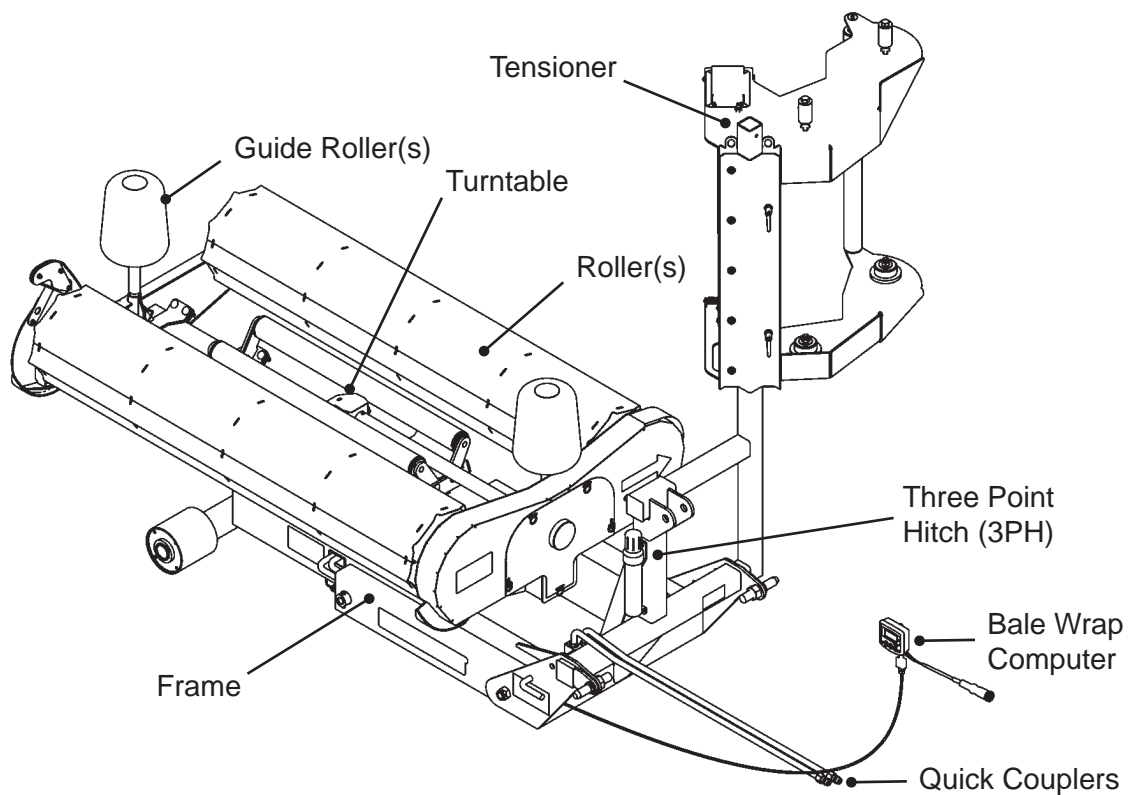

Suitable Wrapping Timeframe

Use a hard-core baler to make the well-shaped and firm bales necessary for successful wrapping. Bales are best wrapped as soon as possible after baling. If bales are left unwrapped they will sag and lose shape. Heating will start soon after baling and protein quality will be lost. It is desirable to wrap within four hours. In an emergency, the bales can be left 12 to 16 hours.

The Tubeline wrapper makes timely harvest possible by reducing the dependence on the weather. It is much easier to get to wilt silage than to make dry hay. This also extends the working day, as the correct moisture to bale extends earlier and later in the day.

For more information visit <http://tubeline.ca/silage.php>.

Bale Sizes

The TL1000R will wrap round bales **up to** 6' in diameter and 5' long. It will **NOT** wrap square bales.

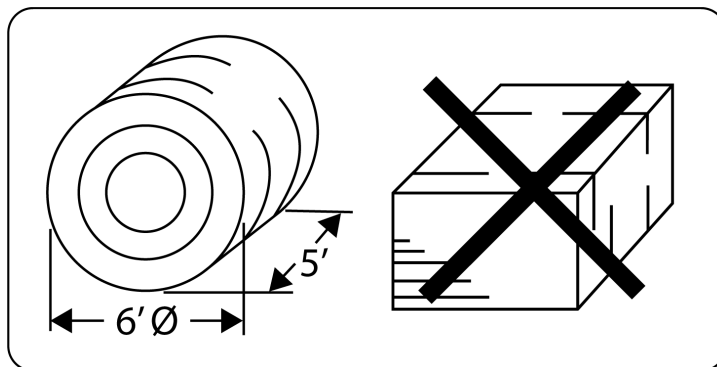

Specifications

Machine Length	104"
Machine Width	80"
Machine Height	84"
Machine Weight	1600 lbs
Drive Type	Hydraulic
Minimum Hydraulic Flow	6 GPM @ 2500 PSI
Hitch Type	Category II 3 Point Hitch
Film Width	30" (x2)
Offset Twin Wrap	Fixed 4"
Bale Guides	Adjustable (4'-5')

Section 2: Safety

NOTE: This safety alert symbol is found throughout this manual to call your attention to instructions involving yourself and others working around the machine.

WARNING: Failure to follow these instructions can result in injury or death!

This symbol means:

Attention! Become Alert! Your Safety is involved!

Signal Words are used in this book.

CAUTION: Indicates a potentially hazardous situation that may result in injury.

WARNING: Indicates a potentially hazardous situation that could result in serious injury or death.

DANGER: Indicates a hazardous situation that needs to be avoided. It is you the operator that needs to be aware of these dangers.

If you have any further questions, please contact your dealer or Tubeline Manufacturing Ltd.

Safety Guidelines

Safety of the operator is paramount. To avoid personal injury study the following precautions and insist those working with you or for you, follow them.

In some cases images in this manual may show shielding removed. This is only to show a view behind the shield. Keep all the shields in place. If they become faulty and fail to work replace them. They are for your safety, do not operate the equipment with them removed.

Replace any decals that may be missing or that are not readable. Location of the decals is indicated in this manual.

Do not operate this machine while under the influence of drugs or alcohol.

Review the safety instructions with all users annually.

This equipment should not be operated by children, or with those unfamiliar with the operation of the machine. Do not allow persons to operate this machine until they have read this manual and/or were instructed by a qualified person.

Do not paint over, remove or deface any safety signs or warning decals on your equipment. Observe all safety signs and practice the instructions on them.

Before Operation

- Carefully study and understand the manual or be trained by an experienced operator.
- Do not wear loose clothing that may get caught in moving parts.
- Visually inspect the machine to make sure no parts are loose or missing.
- Be sure that no tools are left on the machine.
- Do not hurry the learning process. Familiarize yourself with one system before trying the next.
- Practice by running the machine through its paces without a bale on the machine until you are comfortable and familiar with the operation.

Storage & Maintenance

With regular upkeep and careful storage this machine will serve you well for many years. Store the machine in a cool dry place. It is recommended that you tighten the drive chains after the first day of use every year. Also grease the drive chains before storing the TL1000R, replace any removed shields.

Decal Locations

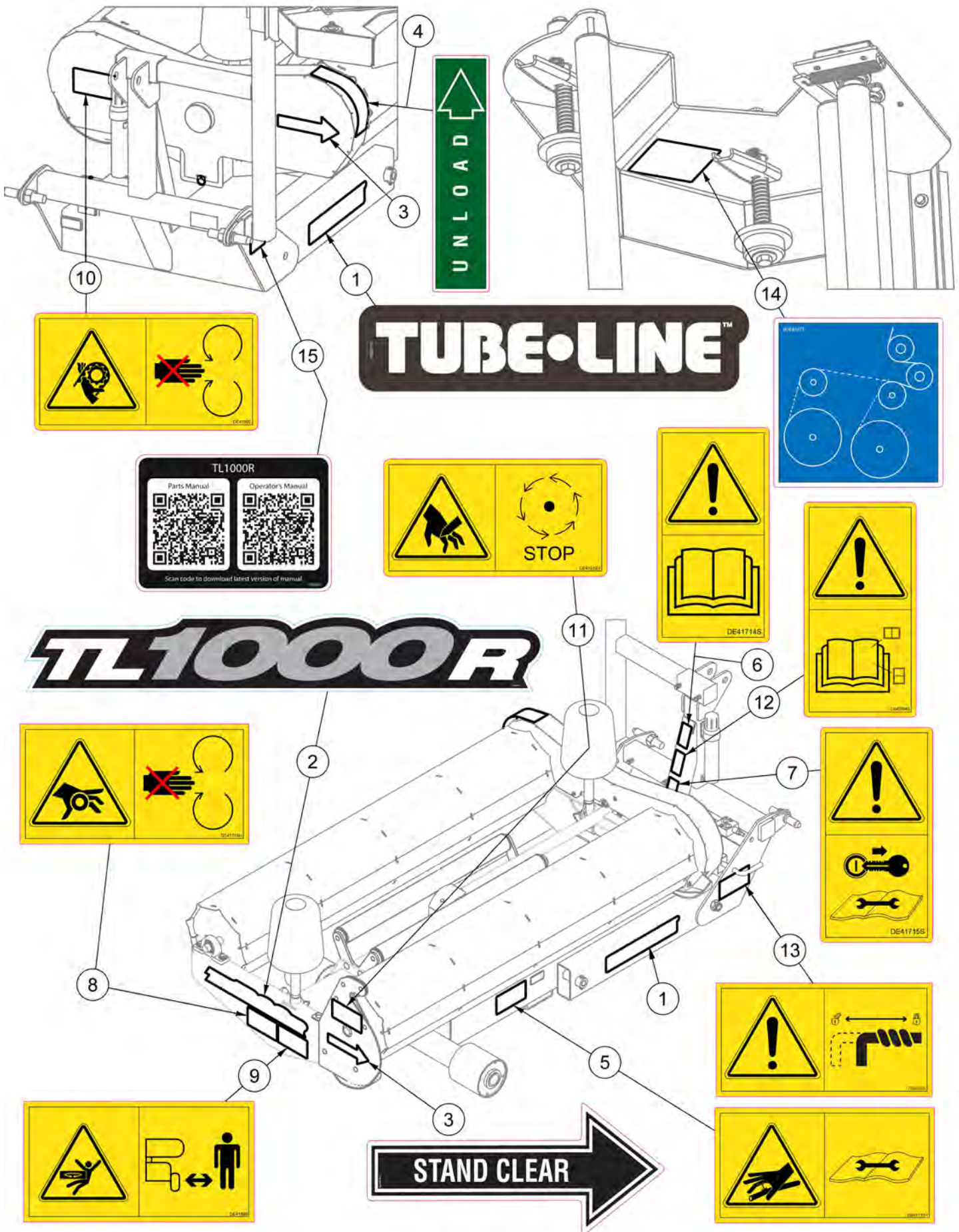

Decal Locations

ITEM	QTY	PART NUMBER	DESCRIPTION
1	2	DE28146	Tubeline Decal 4" x 16"
2	1	DE36073	Decal Model Number for TL1000R
3	2	DE36075	Decal for TL1000R - Stand Clear RH
4	1	DE36080	Decal for TL1000R - Unload
5	1	DE41713H	ISO Decal - High Pressure Fluid Horizontal
6	1	DE41714S	ISO Decal - Read Operator's Manual (50mm X 96mm)
7	1	DE41715S	ISO Decal - Remove Key Before Repair (50mm X 96mm)
8	1	DE41716H	ISO Decal - Shaft Entanglement Horizontal
9	1	DE41899	ISO Decal - Stand Clear of Indi Wrapper
10	1	DE41902	ISO Decal - Chain Entanglement
11	1	DE41913H	ISO Decal - Stop Moving Parts Before Handling
12	1	DE42784S	ISO Decal - Read OM Decal Section (50mm x 96mm)
13	1	DE42858	ISO Decal - TL1000R Transport Lock
14	1	DE43227	TL1000R Tensioner Wrap Decal
15	1	DE50025	TL1000R QR Code

Safety Decals

Item 1 on [pg. 1-3](#)

Part No: DE28146 - Both Sides of Frame



Item 3 on [pg. 1-3](#)

Part No: DE36075 - Corners of Turntable

Shows direction of turntable direction.



Item 14 on [pg. 1-3](#)

Part No: DE43227 - Inside Bottom Face of Tensioner

Follow this diagram when loading plastic rolls onto the tensioner.

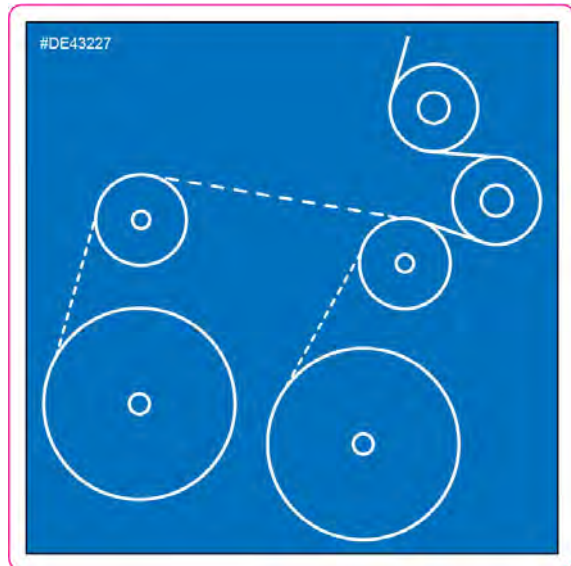

Item 4 on [pg. 1-3](#)

Part No: DE36080 - Dump Side of Turntable

This decal must be turned towards bale dump side before tilting frame.



Item 15 on [pg. 1-3](#)

Part No: DE50025 - Frame Front Left Corner

Scan the QR code to download the latest version of manual.



Item 5 on [pg. 1-3](#)

Part No: DE36073 - Rear Face of Turntable



Safety Decals

Item 5 on [pg. 1-3](#)

Part No: DE41713H - Rear Right of Folding Frame Do not use hand to check for hydraulic leaks, refer to operators manual for maintenance instructions.

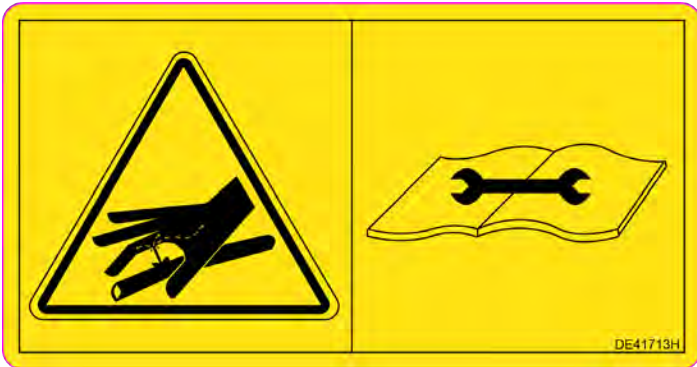

Item 6 on [pg. 1-3](#)

Part No: DE41714 - Inside Face of 3 Point Hitch Upright Tube

Read and understand manual before operating machine.



Item 7 on [pg. 1-3](#)

Part No: DE41715 - Inside Face of 3 Point Hitch Upright Tube

Remove key from power unit before attempting any maintenance on this machine.



Item 8 on [pg. 1-3](#)

Part No: DE41716H - Rear Face of Turntable Keep hands away from shaft ends while machine is operating.



Item 9 on [pg. 1-3](#)

Part No: DE41899 - Rear Face of Turntable Stand clear of wrapper while turntable is spinning.

Safety Decals

Item 10 on [pg. 1-3](#)

Part No: DE41902 - Front Face of Turntable

Do not remove shields before drive components have completely stopped. Keep hands away while machine is in operation.

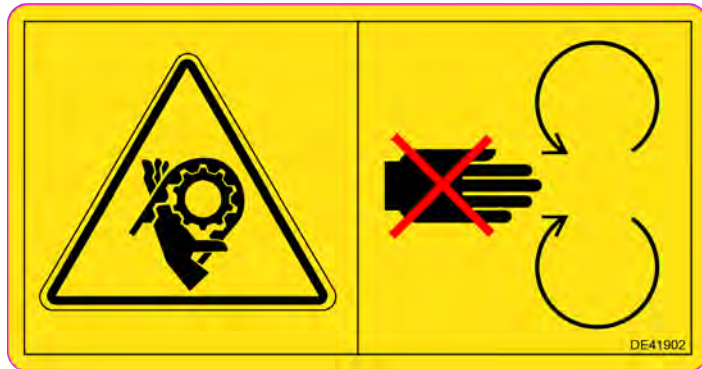

Item 11 on [pg. 1-3](#)

Part No: DE41913H - Rear Right Face of Turntable

Wait until all machine components have stopped moving before touching.



Item 12 on [pg. 1-3](#)

Part No: DE42784 - Inside Face of 3 Point Hitch Upright Tube

Read and understand decal section of manual before operating this machine.



Item 13 on [pg. 1-3](#)

Part No: DE42858 - Front Right Side of 3 Point Hitch Frame

Lock dump frame before transporting. Unlock before wrapping.



WARNING

Your best assurance against accidents or damage to the machine is to know how it operates. If you do not understand a portion of the manual or a function of the wrapper, please contact your dealer or an experienced operator.

Section 3: Initial Setup

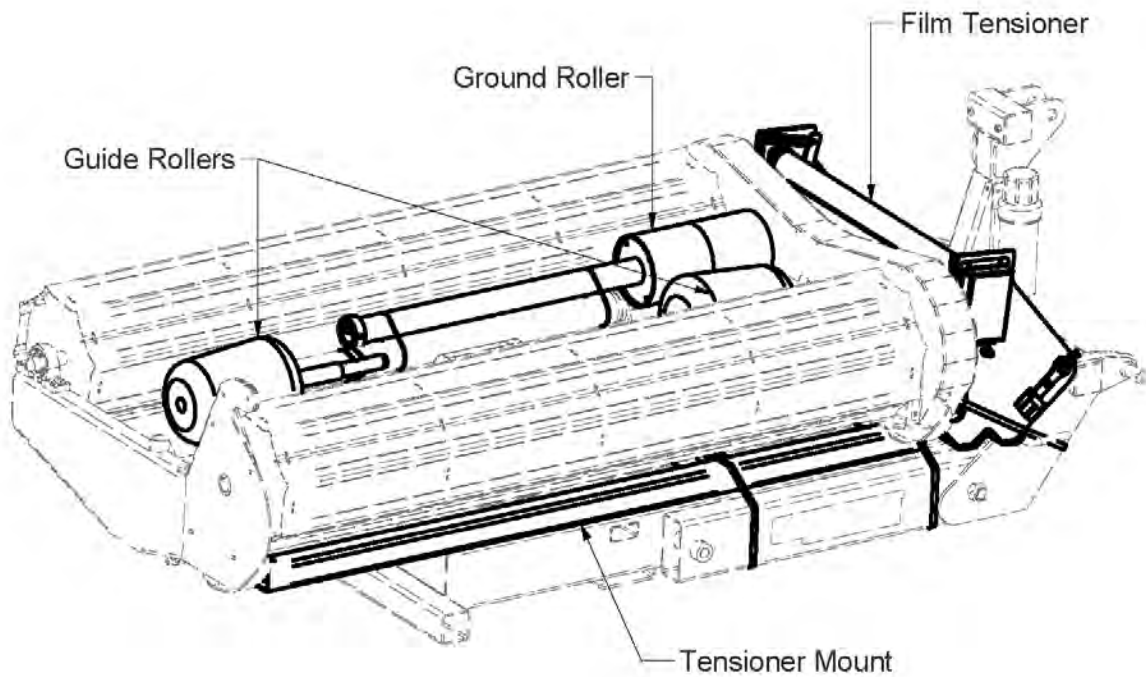

- Remove all parts banded and wired to main frame and set aside.
- Remove monitor, wiring harness and manuals from shipping location behind end shield (35090).

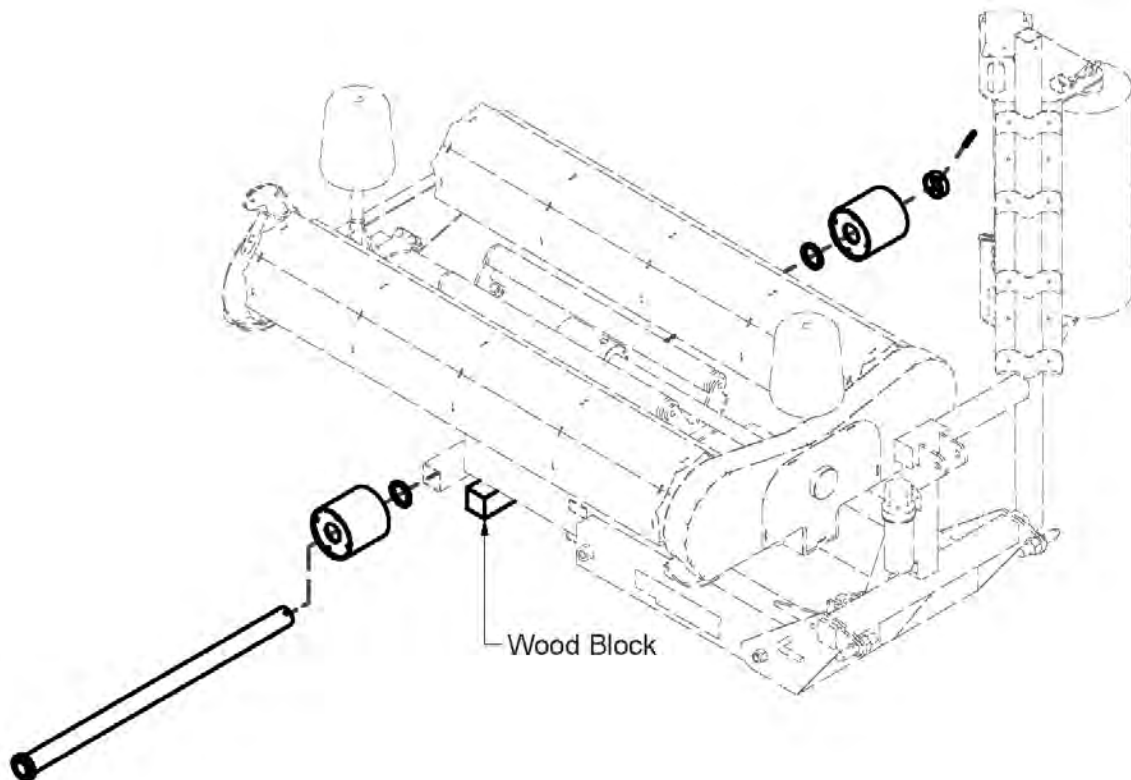

- Lift rear of frame and support with a suitable block of wood. (To allow roller wheel installation)
- Remove one roller wheel from shaft and slide into rear frame tube.
- Slide second roller onto shaft and secure with collar and provided bolt (or pin).

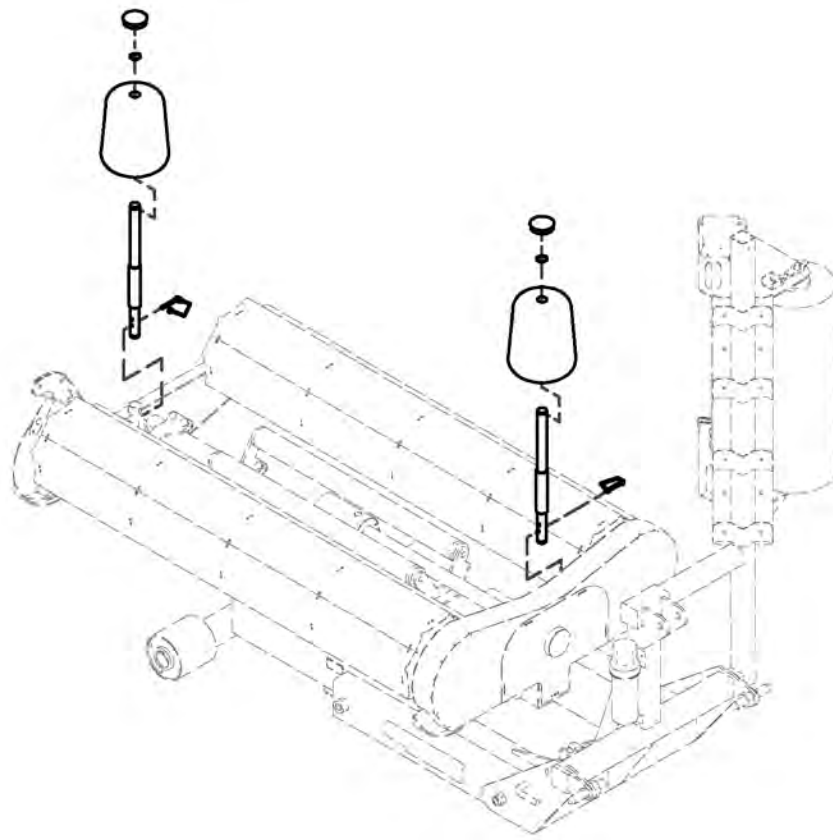

- Install both guide rollers into holders and fasten with lock pin. Guide rollers should be centered on the frame tube and positioned so that the bale width will fit nicely between rollers.

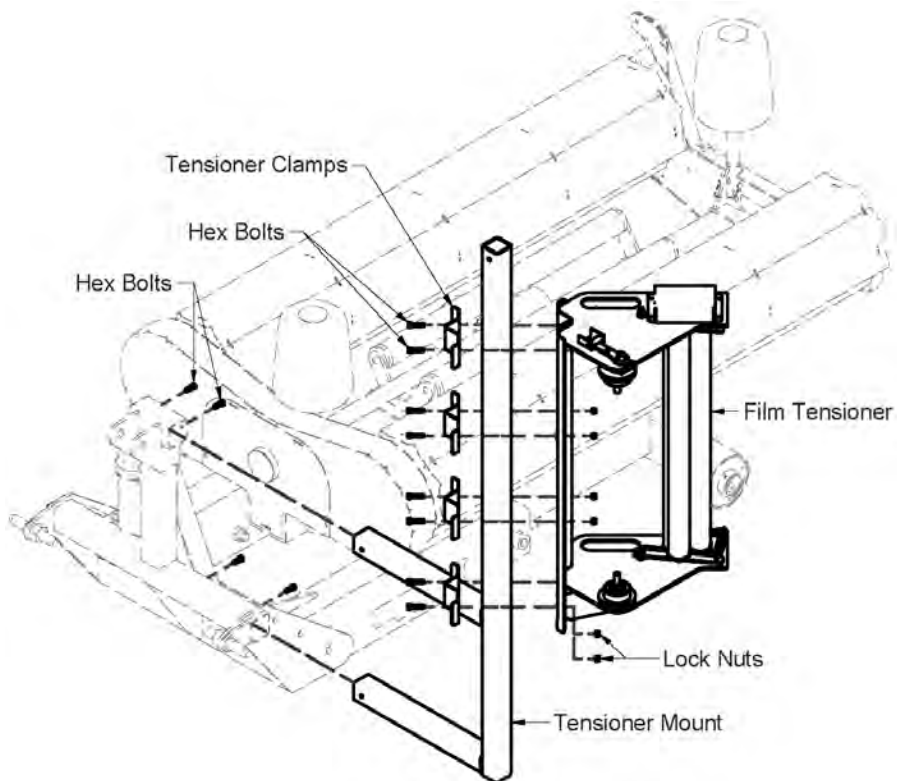

- Slide tensioner mount (35099) all the way into square tube at front of machine and secure with 4 locking bolts provided.
- Mount film tensioner to frame with clamps. See parts illustration for proper positioning. For bales less than 5' in diameter the lower clamp should be below the horizontal frame tube.

NOTE: Adjust up or down so that the wrap is applied across the mid section of the bale.

Electrical Connection

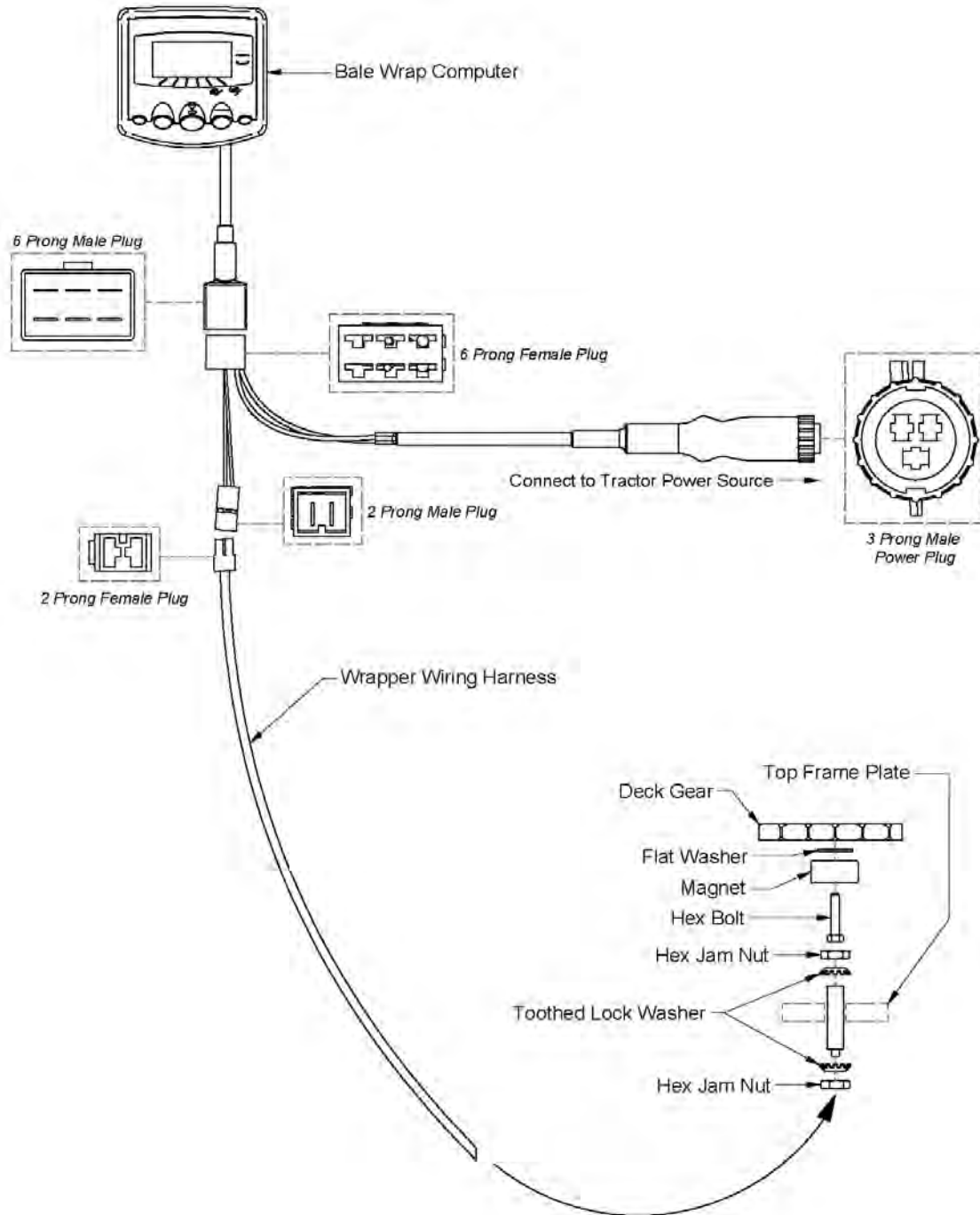

- Cut tie straps securing wrapper wiring harness to frame & connect to two prong plug in wiring harness.
- Mount Wrap Computer to suitable location on tractor with mounting hardware provided. Connect 6 pin plug from computer to wiring harness.
- Connect 3 prong male plug to power source in tractor. If tractor is not equipped with a matching female plug, one will need to be obtained and installed. Contact your local parts dealer.

Section 4: Adjustments and Repairs

Miter Gear Replacement

- Remove cover, pulling off the silicon seal.
- Remove gears by taking nuts off of upright gear, sliding horizontal driveshaft towards driveline to allow horizontal bevel gear to slide off shaft.
- Install new miter gear(s) by tightening nuts on upright gear, then holding horizontal gear in position while sliding drive shaft back through it.
- Gears should mesh together so that they are 2 3/4" from bottom to center and do

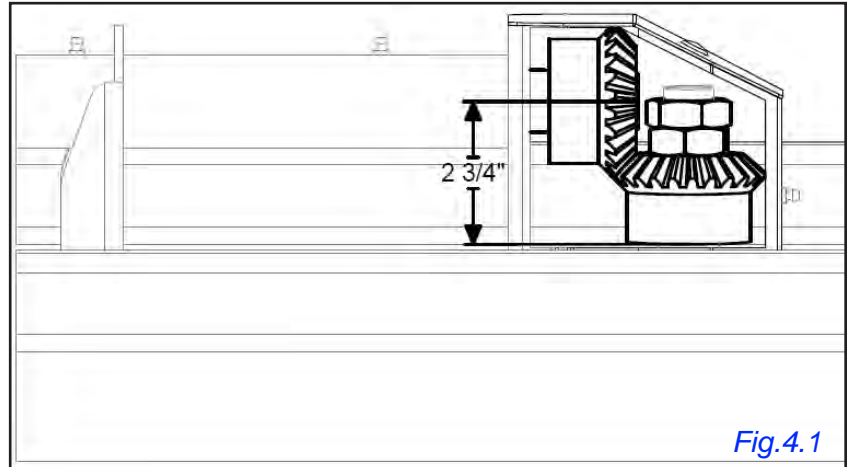

not bind. Front faces are 90° to each other. (Fig.4.1)

- Apply gear oil before reattaching shield, making sure to reseal with silicon to avoid contamination and leak.
- Refill grease box with outer grease zerk, checking level by removing cap. Reinsert cap.

Tensioner Adjustment

NOTE: It is much easier to change the tensioner height when there are no plastic rolls installed. Use a jack if it is too difficult to lift.

1. Turn the top locking handle **(A)** clockwise to loosen.
2. Loosen the bottom locking handle **(B)** slowly, just enough that the tensioner will move.
3. Raise or lower the tensioner **(C)** so that plastic film will be applied to the middle of the bale.
4. Retighten both handles to lock tensioner to its desired height. (Fig.4.2)

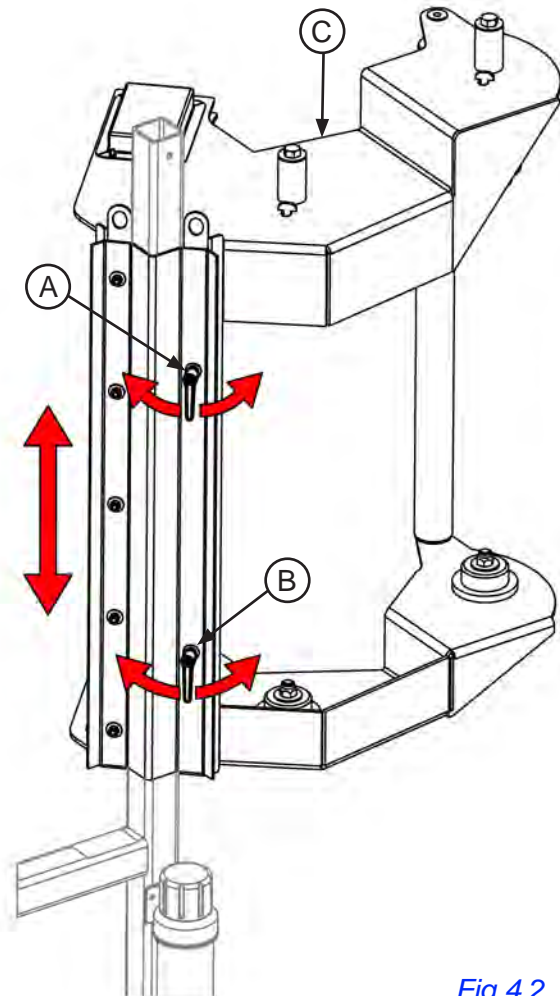

Guide Roller Adjustment

Bale guide rollers (**B**) may need to be adjusted to match bale size. Both guide rollers should be moved the same distance to keep the bale centered on the turntable rollers.

5. Loosen 4 nuts (**C**) locking the clamps in place.
6. Move roller assembly to desired position.
7. Tighten nuts again to lock in new position.

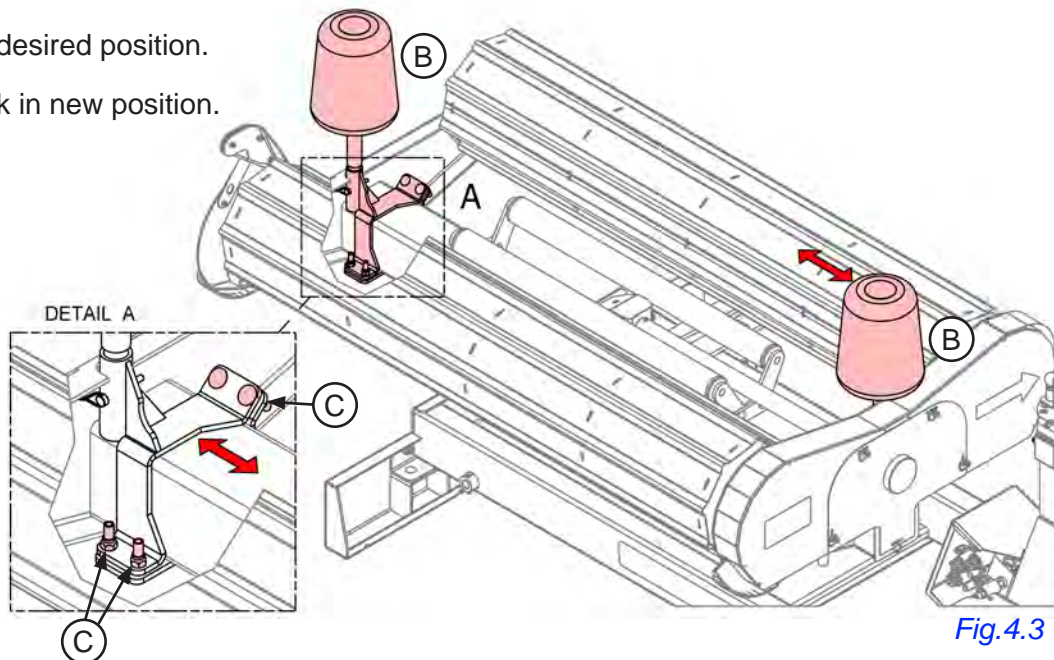

Fig.4.3

Roller Chain Adjustment

It is common over time for the main roller chains to develop slack, resulting in the main rollers not turning smoothly. To extend the life of the chains and continue wrapping smoothly, move the idler sprockets further into the chain to take up the slack.

1. Lift twist lock tabs (**A**) and remove 35088 - Chain Cover (**B**).
2. Loosen the nut (**C**) of the top and or bottom idler sprocket assembly.
3. Move the sprocket assembly along its curved track to tighten, or loosen the roller chains (**D**).
4. Tighten nut (**C**) to lock sprocket assembly in its new position.
5. Replace Chain Cover and fasten with twist lock tabs.

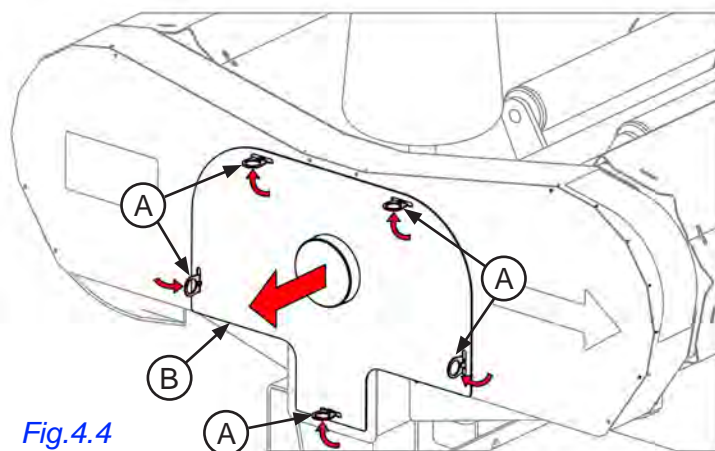

Fig.4.4

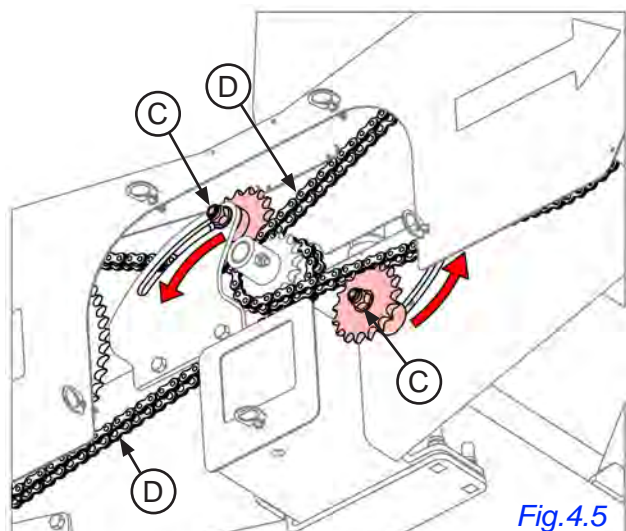

Fig.4.5

Section 5: Operating Procedure

We suggest the following method of operating the TL1000R Tubeline Wrapper.

Before you start wrapping your bales you will need to attach the wrapper to the 3 point hitch on your tractor. You will also need to install a plastic film roll(s) to wrap your bales with.

Tractor Hookup

To hookup the TL1000R to a tractor:

1. Connect 3 point hitch arms to pins on front of wrapper.
2. Connect hydraulic quick couplers on end of hoses to rear tractor hydraulic outlet ports, see [Fig.5.2](#).
3. Connect 3 prong plug wire harness to power outlet or adaptor in tractor cab.
4. Set tractor auxiliary hydraulic flow rate to 6 GPM.

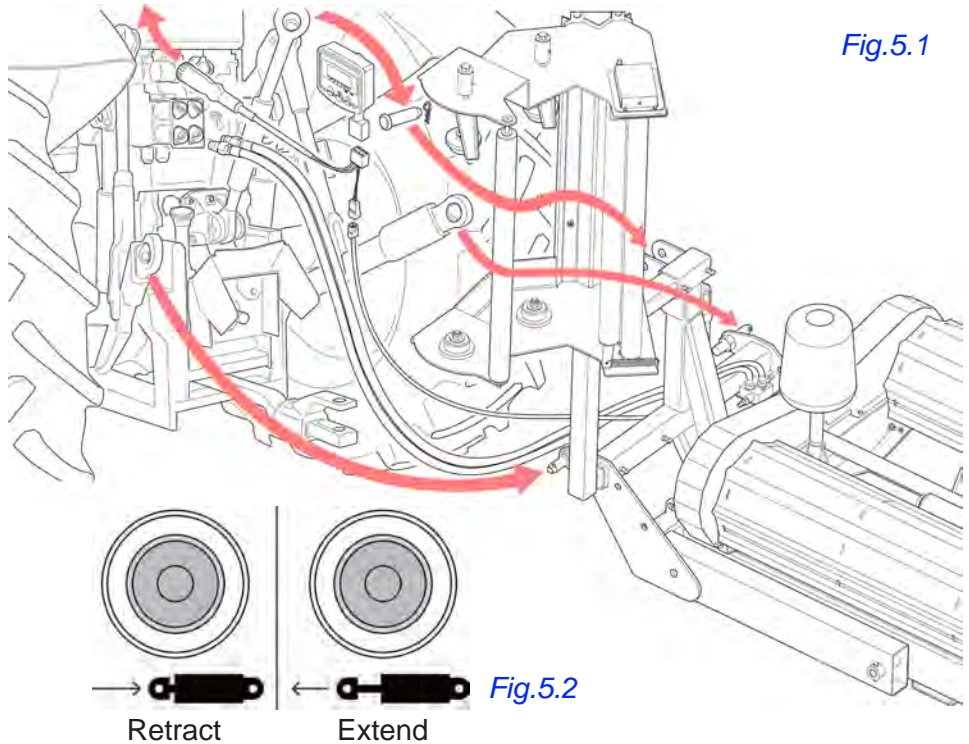

Wrap Operation Setup



WARNING: Bystanders should always keep a safe distance from the wrapper during operation.

Choose a flat wrapping site, lower the machine to the ground.

Unlock the transport spring pin, see [Transportation, pg.5-5](#).

Adjust the bale guide rollers to the proper position for the length or width of the bales. Position rollers so that bale is centered between them. See [Guide Roller Adjustment, pg.4-2](#).

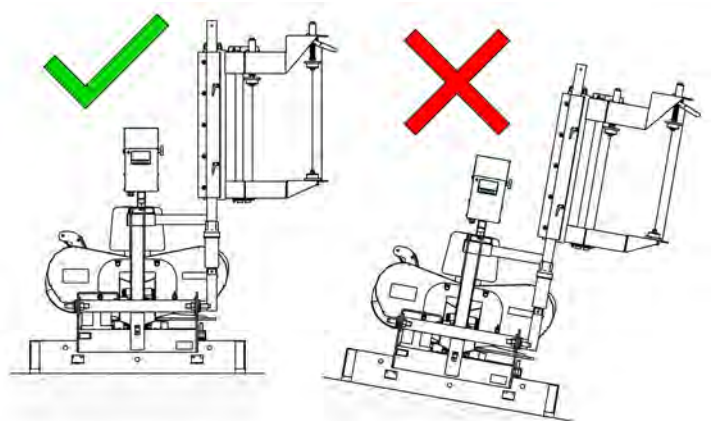

Fig.5.3

To Install Plastic Wrap Film

1. Raise spring loaded plastic holders.
2. Lift plastic rolls onto lower plastic holders.
3. Guide top of plastic rolls under spring loaded plastic holders.
4. Lift handles to snap spring loaded plastic holders into tops of plastic rolls, this will hold them in place while in use. (*Fig.5.4*)

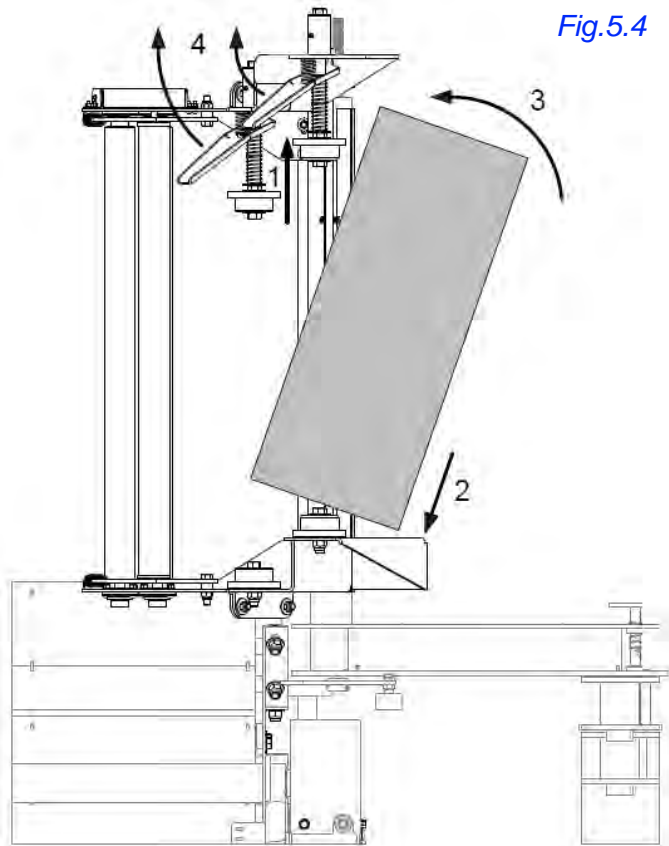

Fig.5.4

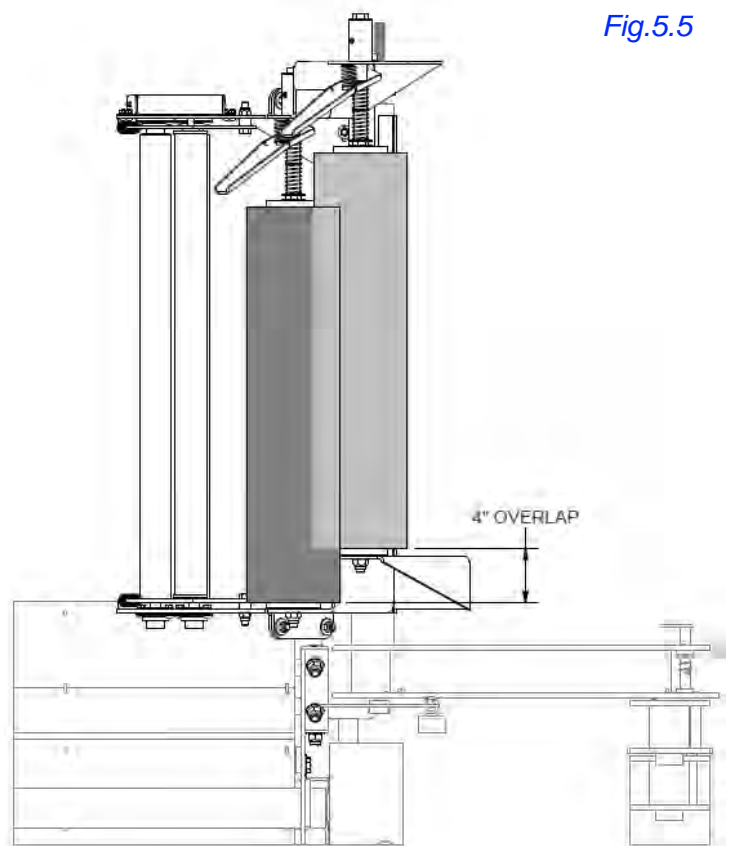

Fig.5.5

Plastic from the factory has a natural tack on the inside. In the event of the plastic being stored for an extended period of time the tack may migrate to the opposite side. To test for tacky side fold plastic inside to inside and pull apart. Fold opposite way (top to top) to determine tackier side.

The rolls of plastic should be installed with the tack on the inside of the plastic film next to the bale silage. The plastic then passes over the plastic and smooth aluminum roller and is threaded through the two knurled aluminum rollers on the Tensioner as shown in the diagram (*Fig.5.6*). The two knurled aluminum rollers rotate at different speeds, causing the plastic to be stretched. It is very important that the plastic goes over the slow roller first and the faster roll second. If there is any question, which is the faster roller:

Turn one roller by hand and watch the speed of the other roller, this should help you determine which is the fast and slow roller. When the plastic is installed correctly, it should stretch tight on the bale to form a smooth wrapped bale. **NOTE:** Plastic rolls have a 4" overlap to provide better sealing (*Fig.5.5*).

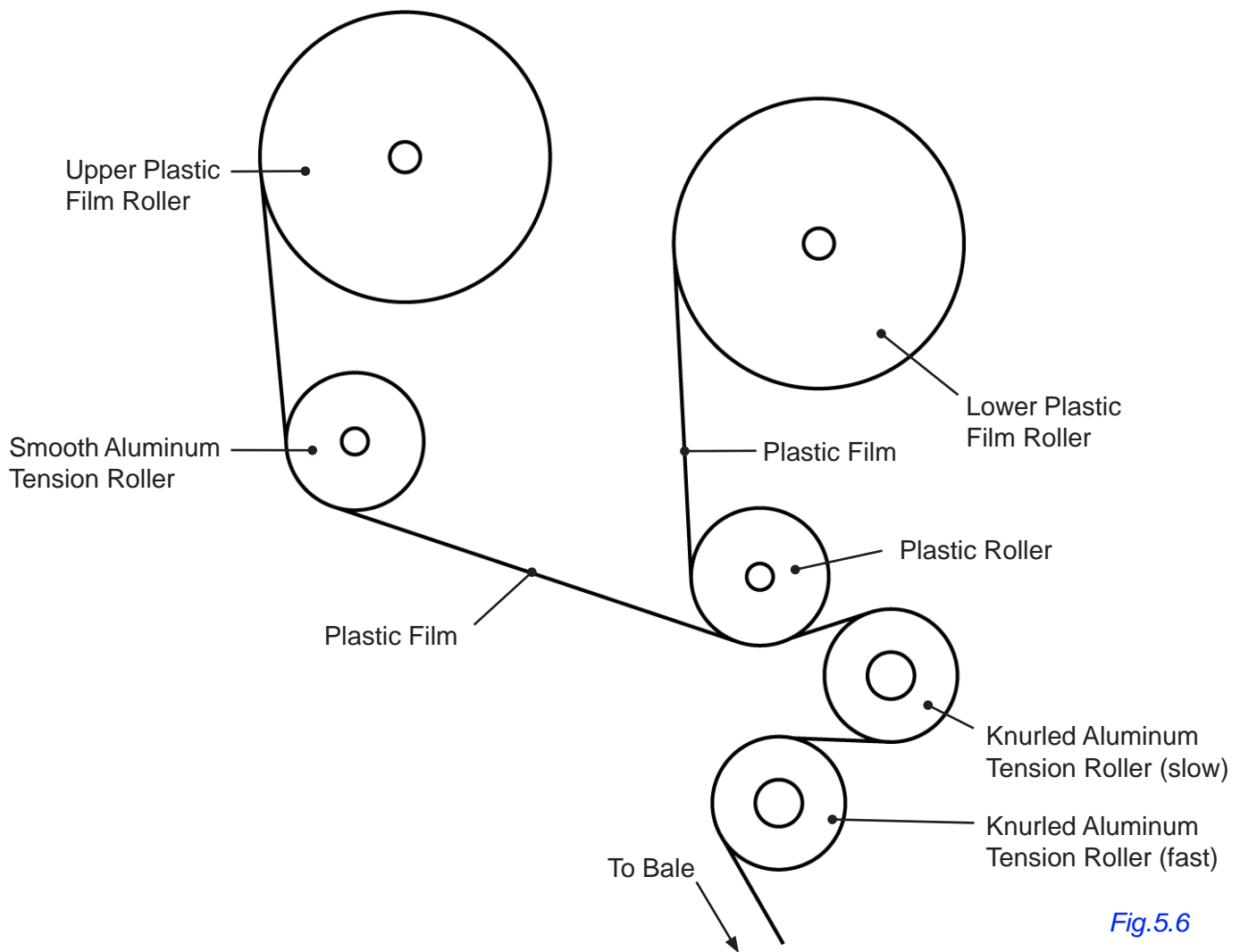

Fig.5.6

Trouble Shooting Plastic Installation

Wrinkles in the plastic with seams between layers easily visible.

Check to determine if the plastic is properly routed through the Tensioner rollers.

Plastic tears between the Tensioner and the bale.

Film spool holders: not turning freely. Lubricate and turn by hand until free. Slave roller not turning freely. Lubricate and turn by hand until free.

Tensioner rolls not turning freely: Loosen the bolts holding the bearing and check if this makes a difference. It may be that the bearings have too much end pressure, in this case re-tighten the bearings and loosen the locking collar on the roller shaft this will allow the shaft to slide in the bearing; re-tighten the bearing collar. The gears can also be meshed too tight; this can be fixed by slightly loosening one set of bearing bolts. Using a hammer and punch, lightly tap the bearing away from the other roller.

CAUTION: Do not use a hammer on the aluminum stretcher rolls.

Poor quality plastic: Use a brand with good tear resistance.

Tack build up on the rollers: Particularly in hot weather. Clean the Tensioner with warm soapy water
 Plastic roll is too hot: In very hot weather the plastic can become soft if left in the sun for long periods of time. In these conditions, the spare rolls should be kept in the shade. After the rolls have been installed on the machine one can be parked on the bottom and a cover can be placed on the top one. Rolls of plastic may catch on the bottom of the bale. If bales are misshaped the roll of plastic may drag on the bottom of the bale, causing the plastic to break.

Plastic Wrap Requirements

Before wrapping continuously, the bale wrap computer early warning alarm should be set, refer to [BWC - Early Warning Alarm, pg.6-3](#). To set this alarm, the amount of turntable rotations to completely wrap a bale once must be known. Follow the formula below to find this value.

Completely wrapping a bale once with a single plastic film roll results in 2 layers; two film rolls results in 4 layers. Thus, when using two rolls, the turntable rotates less, resulting in a faster wrap cycle.

NOTE: If desired number of wrap layers are not multiples of 4 a single roll must be used.

NOTE: It is good practice to periodically check the bales after being wrapped for any torn, split, or punctured plastic film. If the stubble in a particular field tends to puncture the plastic film, it is strongly advised to wrap the bales at the stack, where there may be more control over the ground conditions.

NOTE: Bale wrap layer overlap should be adjusted to be as close to 50% as possible. This will provide a good seal and prevent spoilage.

To find the correct **Target Wrap Layers** value for your bale size:

1. Find X by wrapping a bale until it is completely covered once, counting the number of turntable rotations. Add 1 to this number.
2. Find Y by dividing desired number of layers by 2 for a single roll, or 4 for twin rolls. Example: $Y = 3$ (6 layers / 2) or $Y = 2$ (8 layers / 4). **NOTE:** MUST BE A WHOLE NUMBER.
3. Multiply X by Y to find Z. This is the **Target Wrap Layers** value. $X (7+1) \times Y (6 / 2) = Z (24)$.

Loading Bales

Before placing the first bale onto the rollers make sure the wrapper rollers are parallel to the 3PH mounted tractor's axle. You are ready to load bales when the unload arrow decal on the front right corner of the rollers. Pierce the bale above the midpoint when lifting off the ground or wagon. Load bales over the left or right side of the machine, refer to [Fig.5.7](#).

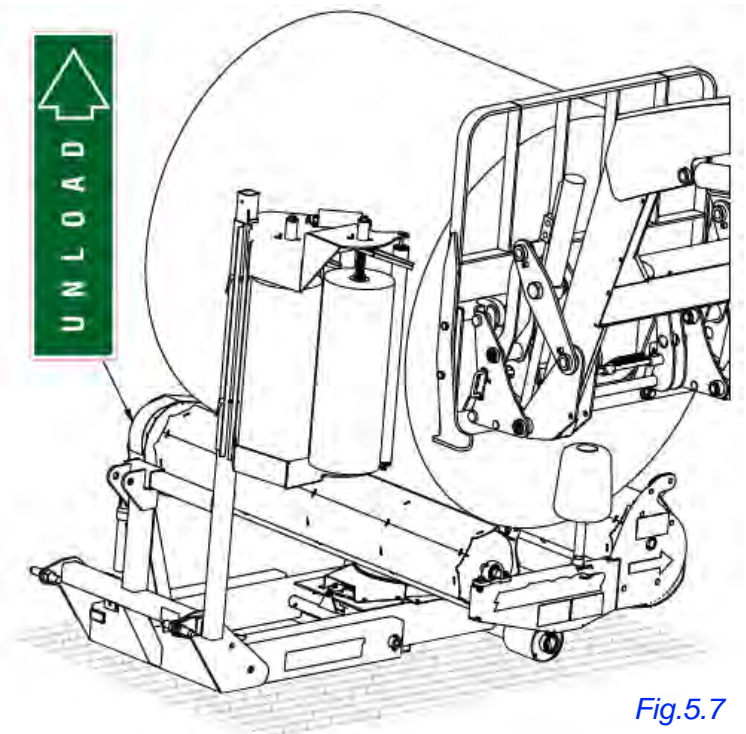

[Fig.5.7](#)

First Bale Wrapping

After placing the first bale onto the wrapper, tie the plastic film edge to the netting/twine of the bale. See [Fig.5.8](#).

The film tensioner should be adjusted so that the wrap is applied to the middle of the bale. Refer to [Tensioner Adjustment, pg.4-1](#) to adjust tensioner as needed until wrap crosses the bale at its midpoint. As a guide, for a 4' or 4.5' diameter bale, the lower clamp, will be just below the cross bar under the tensioner.

Keep the tractor at a steady RPM while engaging the hydraulic motor on the wrapper to allow a smooth wrapping job. The speed of the turntable is controlled by the amount of oil flow from the tractor. If the tractor is equipped with a flow control, set it to achieve the desired RPM. In a tractor without a flow control, the operator will need to control the flow manually with the hydraulic lever and/or engine RPM. A poorly shaped bale, also a very large bale, will require a slower table speed. A smaller, firm, well shaped bale may be able to be wrapped at a faster RPM. However faster speeds may cause the bale to be thrown off the wrapper. Bystanders should always keep a safe distance from the wrapper during operation.

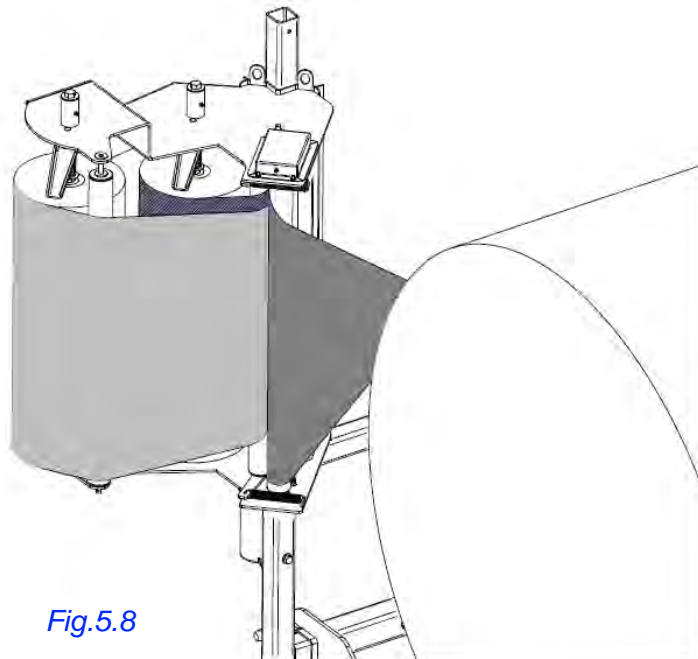

[Fig.5.8](#)

Unloading

Refer to [Fig.5.9](#). To unload a bale make sure the unload arrow decal on the front right corner of the turntable is **POINTING TOWARDS THE FRONT** of the machine, as seen in [Fig.5.7](#).

Raise the 3 point hitch on your tractor slowly. The wrapper's frame rise up **(A)**, while the wrapper tilts back, allowing the bale on the turntable to roll softly and safely to the ground **(B)**.

NOTE: If you have not pulled out the transport pin the whole wrapper will raise off the ground instead of tilting. Refer to [Fig.5.11](#) to unlatch this pin.

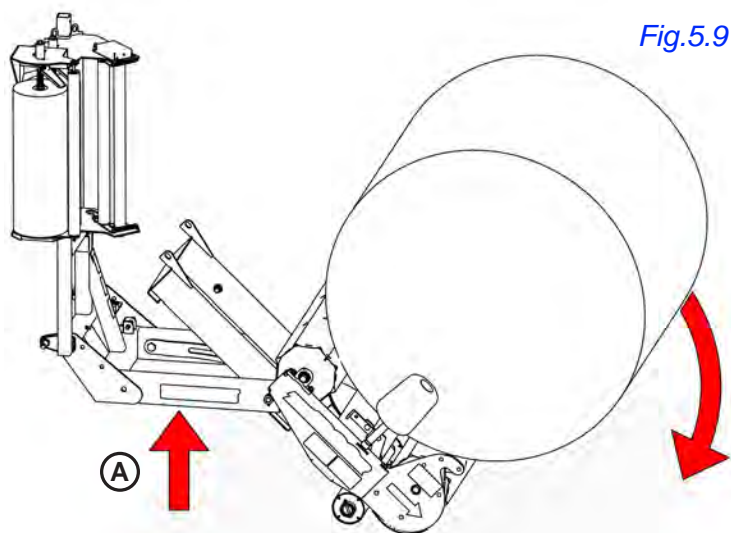

[Fig.5.9](#)

Continuous Wrapping

This machine has a feature that takes away the need to cut the plastic film after each bale is ejected from the turntable. When you load the next bale it will be sitting on top of plastic film stretched across the rollers. As you start wrapping each bale after the initial bale, a knife edge located on the rear left of the turntable will cleanly cut the wrap between the unloaded bale and the wrapper.

NOTE: The turntable **MUST** be parallel with the tractor axle before loading each bale.

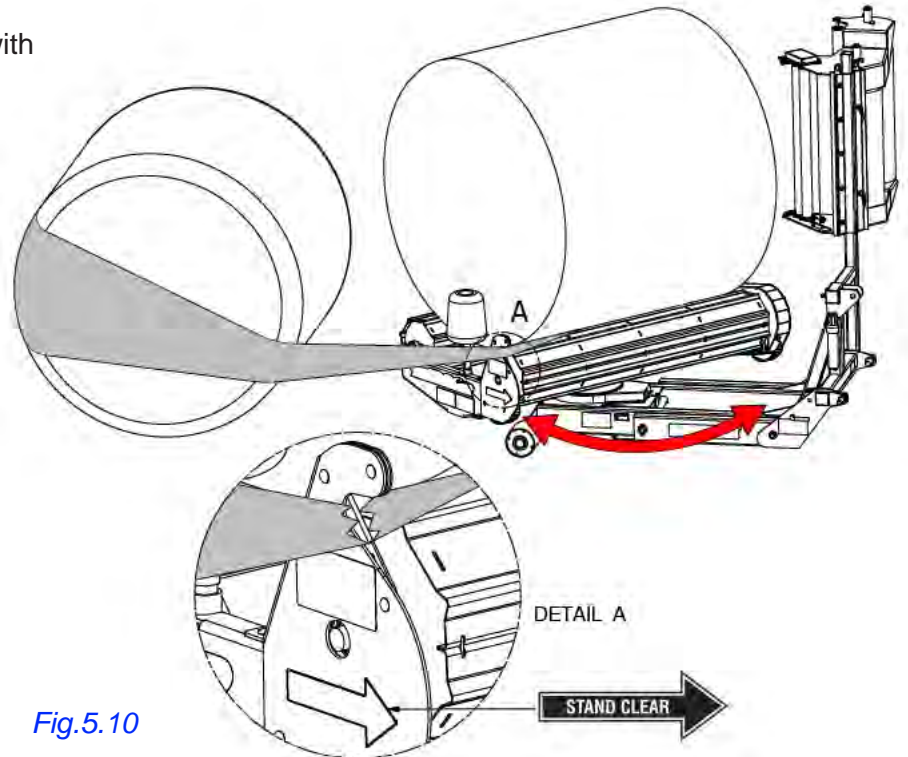

Fig.5.10

Transportation



WARNING: Do **NOT** transport with bale on rollers.

Follow instructions below to prepare the machine for safe transport.

1. Lock turntable by turning and pushing in the transport lock pin. See Fig.5.11.
NOTE: The turntable needs to be in its home position, parallel with the frame.
2. To avoid unravelling, secure plastic rolls on tensioner.
3. Raise wrapper off ground with 3 pint hitch.
4. Know and follow your local road laws and speed limits when transporting.

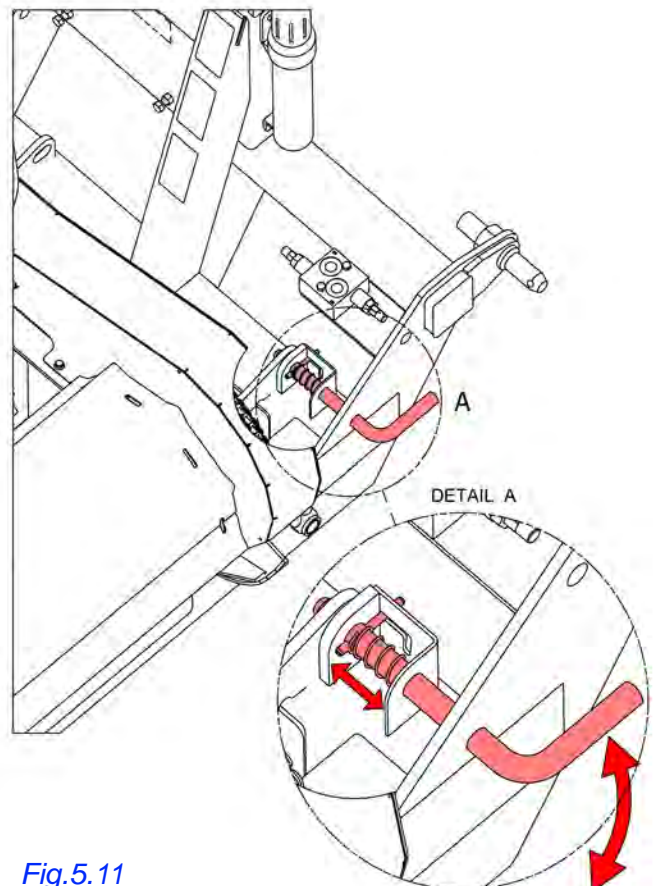

Fig.5.11

Section 6: Bale Wrap Computer (BWC)

BWC - Introduction

Please follow these instructions when operating the Bale Wrap Computer.

The Bale Wrap Computer has 6 channel functions with an illuminated 4 digit LCD display, 3 switches to control all functions and an internal alarm. An external alarm is optional.



The instrument is normally powered on via the vehicle ignition circuit and recalls the function displayed when the instrument was last used.

What can it do?

- Continuously displays the current number of wraps around the bale alongside the desired (Target) number of wraps preset by the operator.
- Sounds an alarm at a preset number of wraps before the target number is reached.
- Automatically senses when the bale wrap sequence ends and records it to each of these memory registers:
 1. Grand Total
 2. Part Total
 3. One of eight selectable Store Totals
- Displays the number of bales wrapped per hour, within any desired time period.
- Displays bale wrapping speed in r.p.m. and sounds an alarm when a preset speed is exceeded.

BWC - Control Switches

There are three (3) switches on the front panel used individually or in combination to programme, set/reset or select a function.

Channel 1	'Normal display (Current/Target no. of wraps)	NORMAL
Channel 2	Store Totals (A-H)	TOTAL ABCD EFGH
Channel 3	Part Total	PART TOTAL
Channel 4	Grand Total	GRAND TOTAL
Channel 5	Bale Wrapping Rate	 / Hr
Channel 6	Bale Wrapping Speed	 / min

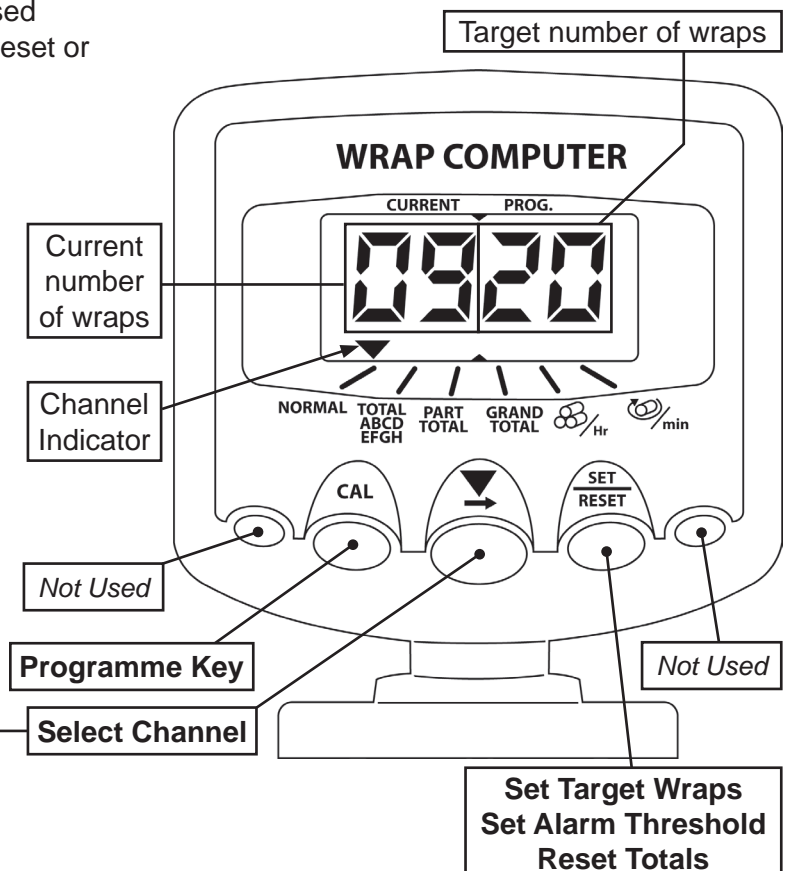

BWC - Channel 1 - Current/Target Wraps Display



to select **NORMAL**.

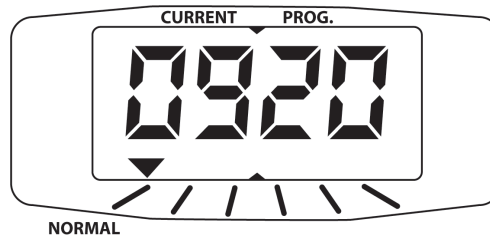

The left hand section shows the current number of wraps and the right hand section shows the target number.

When the current number = Target number, the alarm will sound for 2 seconds and the display will flash. (If set, the early warning alarm sounds beforehand).

Automatic reset of current number to zero normally occurs 3 seconds after the Target number is reached. If additional wraps are added after the Target number is reached, the current number will continue to advance.

BWC - Manually reset Current No. of Wraps to Zero

1. Press



to select **NORMAL**.

2. Press and hold **SET RESET**.



BWC - Program the Target Wraps

1. Press



to select **NORMAL**.

2. Hold **PROGRAM** continuously. *The third digit flashes.*

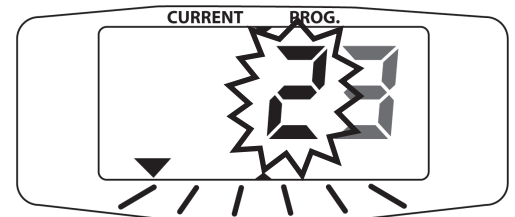

3. Hold **SET RESET** to cycle to the required digit then release, otherwise press once.



The fourth digit flashes.

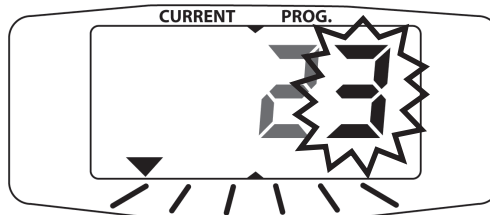

4. Hold **SET RESET** to cycle to the required digit.



5. Release all.

BWC - Early Warning Alarm

An early warning alarm can be programmed to sound from 1 to 9 wraps before the target number is reached. Depending on the setting, the alarm will sound long beeps for up to 8 wraps, short beeps for the final wrap, and then a continuous beep for three seconds.

For example, if the bale requires 22 wraps and you want an alarm at 20 wraps, then set the number to 2.

To effectively disable the alarm, set the number to 0.

1. Press  to select.



2. Hold **PROGRAM**  continuously.



The fourth digit flashes.

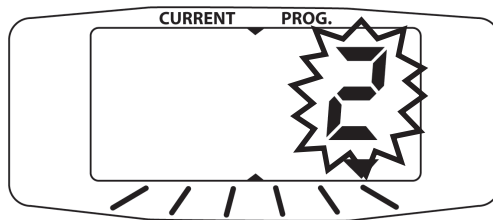

3. Hold **SET RESET**  to cycle to the required digit.



4. Release all.

BWC - Channel 2 - Store Totals

When bale wrap is complete, one of eight pre-selected memory store totals **A, b, C, d, E, F, G, or H**, is automatically advanced by 1. Store totals can be reset individually.

BWC - Display a Store Total.

1. Press  to select **TOTAL**.



The fourth digit displays the current store designation for 2 seconds.

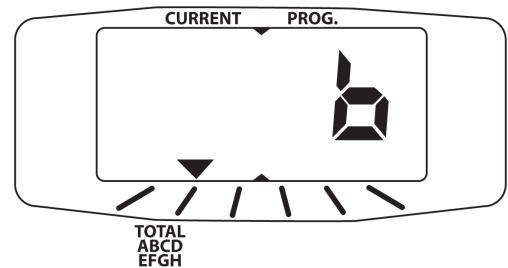

The current total for that store then displays for five seconds, then defaults to channel 1.

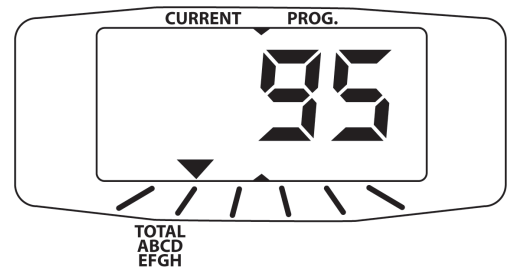

BWC - Select a Store Total

1. Press  to select **TOTAL**.

ABCD
EFGH



2. Select the desired store total (A – H).

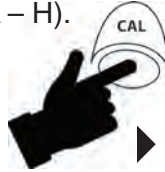

This is now the default store, and subsequent bale counts are stored there until another store is selected.

BWC - Reset a Store Total

1. Press  to select **TOTAL**.

ABCD
EFGH



2. Select the desired store total (A – H).



3. Press and hold **SET RESET**.



BWC - Channel 3 – Part Total

When the bale wrap is complete, the part total is automatically advanced by 1. The part total can be reset at any time.

BWC - Display Part Total

1. Press  to select channel 3 **PART TOTAL**.

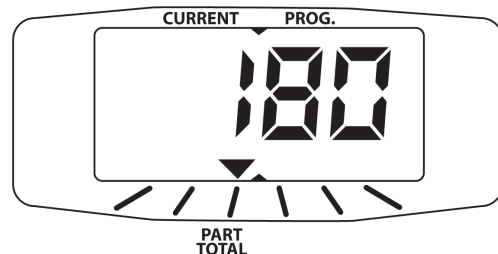

Part total displays for 5 seconds then defaults to channel 1.

BWC - Reset Part Total

2. Press  to select channel 3 **PART TOTAL**.



3. Press and hold **SET RESET**.



BWC - Channel 4 - Grand Total

When the bale wrap is complete, the grand total is automatically advanced by 1. The grand total cannot be reset.

BWC - Display Grand Total

1. Press  to select **GRAND TOTAL**



2. Grand total displays for 5 seconds then defaults to channel 1.

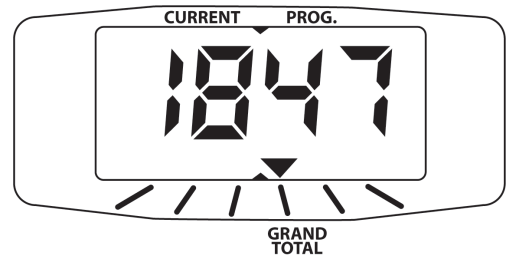

BWC - Channel 5 - Bale Wrapping Rate

Displays number of bales wrapped per hour. The time period over which the rate is averaged may be re-started at any time.

BWC - Display Bale Wrapping Rate

- Press  to select



1. Press  to select



BWC - Reset Timing Period

2. Press and hold **SET RESET**.



BWC - Channel 6 - Bale Wrapping Speed

Displays instantaneous r.p.m. of the bale wrapper at 3 second intervals in the range 10-99 r.p.m. An overspeed alarm will sound if the r.p.m. exceeds a preprogrammable limit. The display will default to this channel and flash for the duration of the overspeeding, subsequently reverting to the 'current/target wraps' display.

BWC - Display Bale Wrapping Speed

- Press  to select

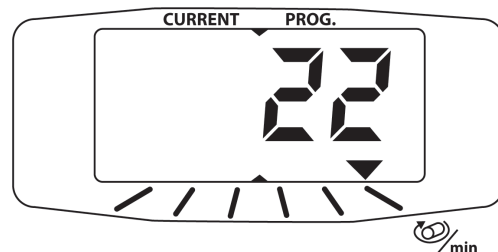

BWC - Program the Overspeed Alarm

1. Switch power on while pressing  .

2. Release  .

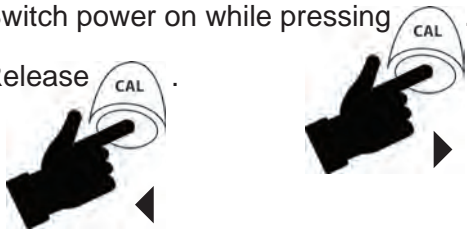

The third digit flashes.

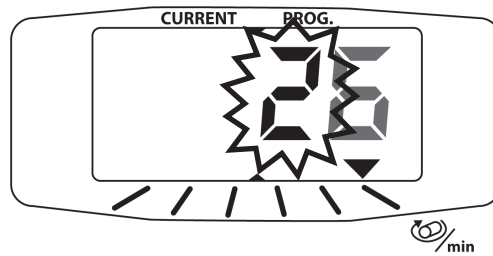

3. Hold **SET RESET**  to cycle to the desired digit, then release, otherwise press once.



The fourth digit flashes.

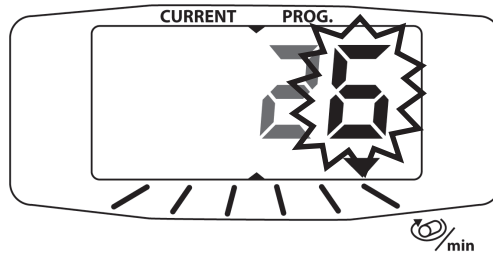

4. Hold **SET RESET**  to cycle to the required digit.



5. Release all.

BWC - Total Reset

If for some reason the data in the instrument is corrupted or the display shows '**PrOg**' then the instrument must be totally reset.

1. Switch power off.
2. Press and hold all 3 control switches.
3. Switch power on.
4. Release all switches.

All instrument settings should be returned to the factory-set values. If the display shows '**PrOg**' again, the instrument may be faulty and must be returned to the manufacturer for inspection and repair.

Section 7: Grease Points

Grease Gun

Use a grease gun to lubricate these areas with a #2 grade all purpose lithium grease before operating season, and monthly during operational season to keep machine in optimum operating condition.

Fig.6.1

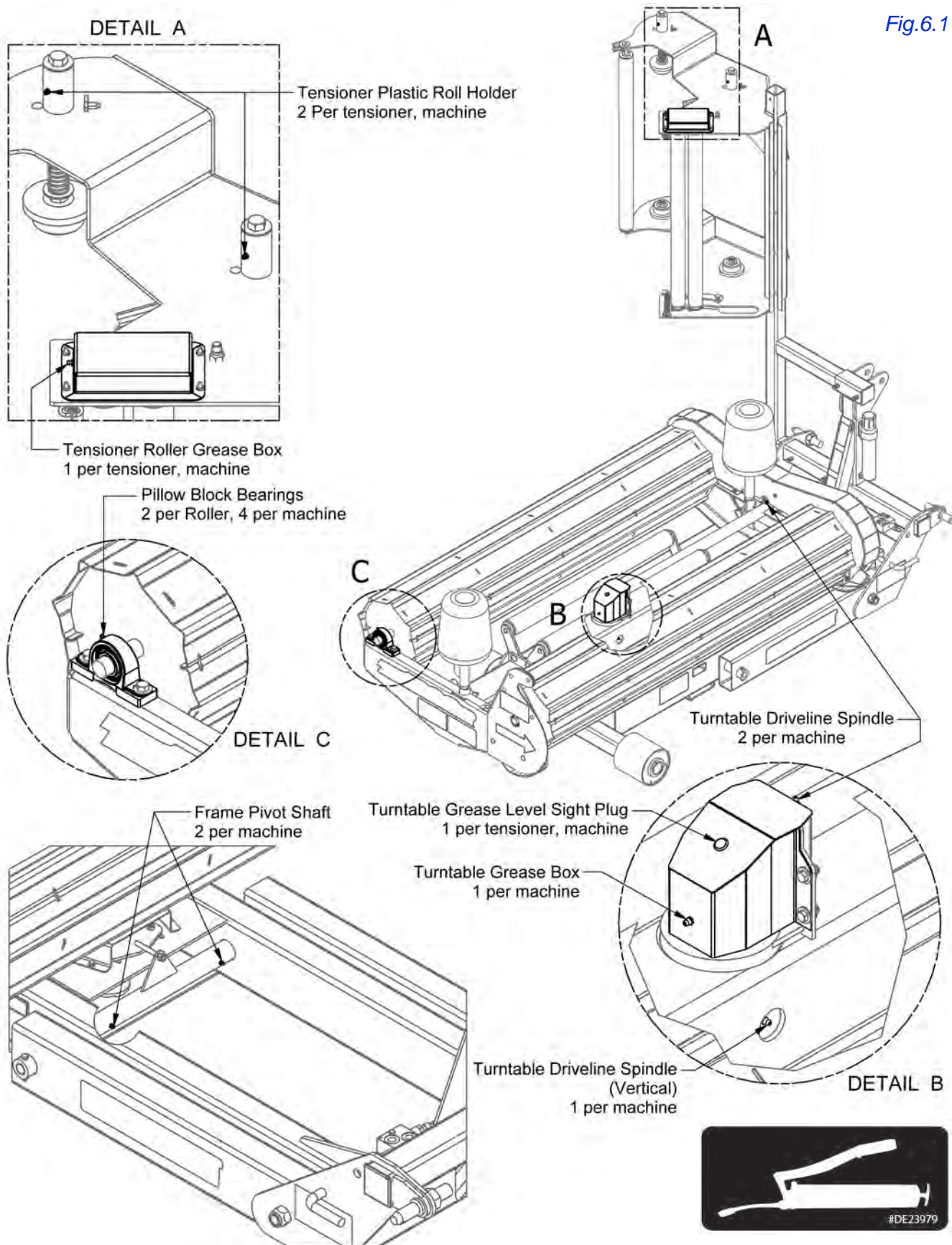

When refilling turntable grease box (*Fig.6.1 - DETAIL B*)







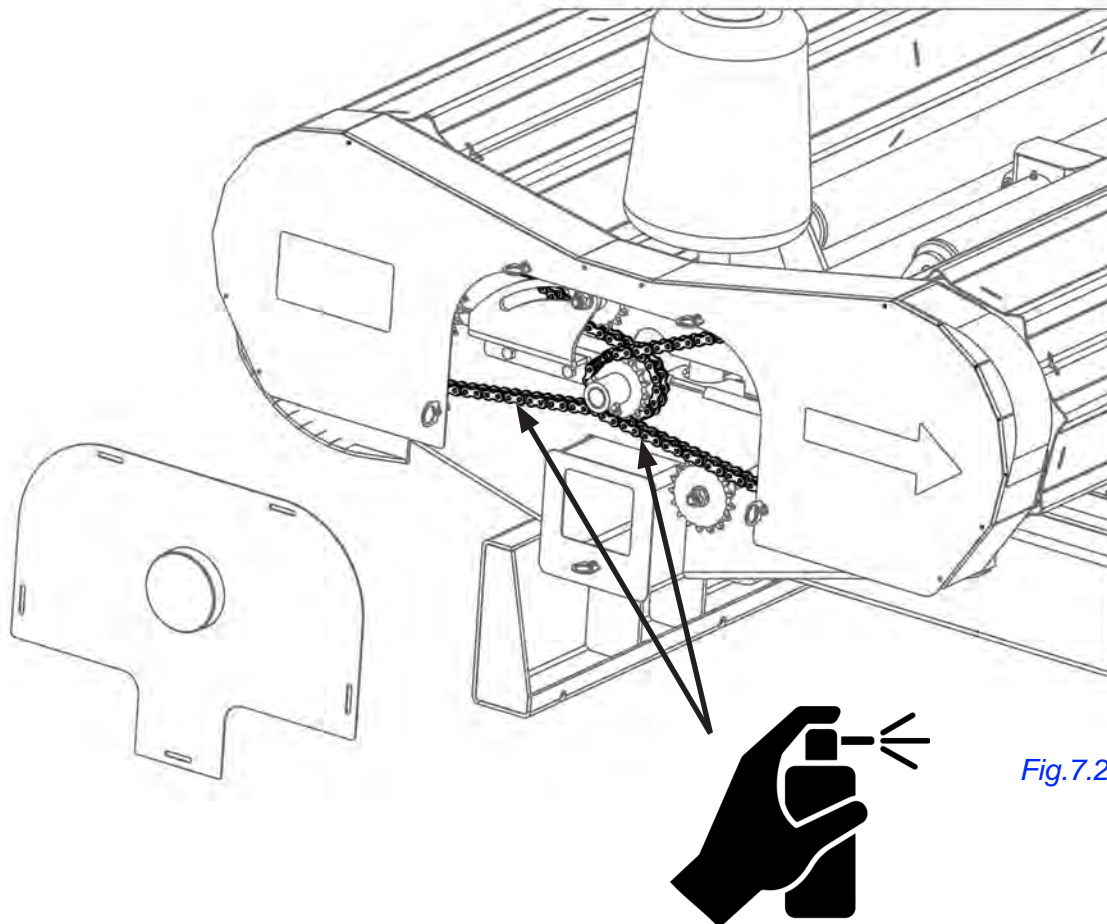



- Remove plug from top of gear box cover to see grease level as it is being filled.
- Fill grease box completely using grease zerk on rear side of shield.
- Reattach plug.

Aerosol Grease

Use a #2 grade penetrating white grease in aerosol form to lubricate the roller chains (*Fig.6.2*) before and after each operating season. Spray chains monthly during regular operational use.



Torque Values - Imperial

SAE Grade and Head Markings	NO MARK	1 or 2 ^b 	5 	5.1 	5.2 	8 	8.2 
	NO MARK	2 	5 			8 	

Size	Grade 1				Grade 2 ^b				Grade 5, 5.1, or 5.2				Grade 8 or 8.2			
	Lubricated ^a		Dry ^a		Lubricated ^a		Dry ^a		Lubricated ^a		Dry ^a		Lubricated ^a		Dry ^a	
	N-m	lb-ft	N-m	lb-ft	N-m	lb-ft	N-m	lb-ft	N-m	lb-ft	N-m	lb-ft	N-m	lb-ft	N-m	lb-ft
1/4	3.7	2.8	4.7	3.5	6	4.5	7.5	5.5	9.5	7	12	9	13.5	10	17	12.5
5/16	7.7	5.5	10	7	12	9	15	11	20	15	25	18	28	21	35	26
3/8	14	10	17	13	22	16	27	20	35	26	44	33	50	36	63	46
7/16	22	16	28	20	35	26	44	32	55	41	70	52	80	58	100	75
1/2	33	25	42	31	53	39	67	50	85	63	110	80	120	90	150	115
9/16	48	36	60	45	75	56	95	70	125	90	155	115	175	130	225	160
5/8	67	50	85	62	105	78	135	100	170	125	215	160	240	175	300	225
3/4	120	87	150	110	190	140	240	175	300	225	375	280	425	310	550	400
7/8	190	140	240	175	190	140	240	175	490	360	625	450	700	500	875	650
1	290	210	360	270	290	210	360	270	725	540	925	675	1050	750	1300	975
1-1/8	400	300	510	375	400	300	510	375	900	675	1150	850	1450	1075	1850	1350
1-1/4	570	425	725	530	570	425	725	530	1300	950	1650	1200	2050	1500	2600	1950
1-3/8	750	550	950	700	750	550	950	700	1700	1250	2150	1550	2700	2000	3400	2550
1-1/2	1000	725	1250	925	990	725	1250	930	2250	1650	2850	2100	3600	2650	4550	3350

DO NOT use these values if a different torque value or tightening procedure is given for a specific application. Torque values listed are for general use only. Check tightness of fasteners periodically.

Shear bolts are designed to fail under predetermined loads. Always replace shear bolts with identical grade.

Fasteners should be replaced with the same or higher grade. If higher grade fasteners are used, these should only be tightened to the strength of the original.

Make sure fasteners threads are clean and that you properly start thread engagement. This will prevent

them from failing when tightening.

Tighten plastic insert or crimped steel-type lock nuts to approximately 50 percent of the dry torque shown in the chart, applied to the nut, not to the bolt head. Tighten toothed or serrated-type lock nuts to the full torque value.

^a "Lubricated" means coated with a lubricant such as engine oil, or fasteners with phosphate and oil coatings. "Dry" means plain or zinc plated without any lubrication.

^b Grade 2 applies for hex cap screws (not hex bolts) up to 152 mm (6-in.) long. Grade 1 applies for hex cap screws over 152 mm (6-in.) long, and for all other types of bolts and screws of any length.

Torque Values - Metric

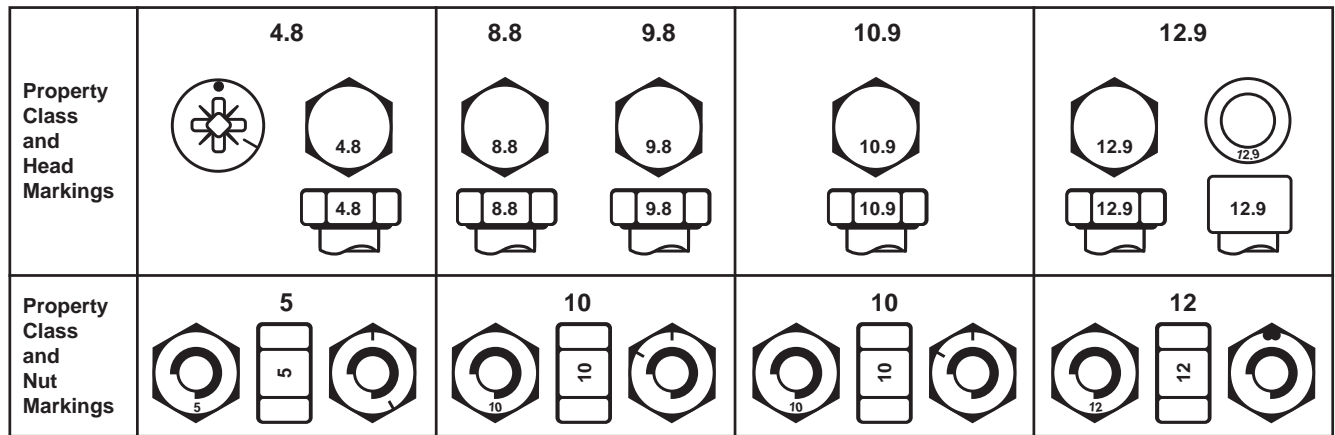

Size	Class 4.8				Class 8.8 or 9.8				Class 10.9				Class 12.9			
	Lubricated ^a		Dry ^a		Lubricated ^a		Dry ^a		Lubricated ^a		Dry ^a		Lubricated ^a		Dry ^a	
	N-m	lb-ft	N-m	lb-ft	N-m	lb-ft	N-m	lb-ft	N-m	lb-ft	N-m	lb-ft	N-m	lb-ft	N-m	lb-ft
M6	4.8	3.5	6	4.5	9	6.5	11	8.5	13	9.5	17	12	15	11.5	19	14.5
M8	12	8.5	15	11	22	16	28	20	32	24	40	30	37	28	47	35
M10	23	17	29	21	43	32	55	40	63	47	80	60	75	55	95	70
M12	40	29	50	37	75	55	95	70	110	80	140	105	130	95	165	120
M14	63	47	80	60	120	88	150	110	175	130	225	165	205	150	260	190
M16	100	73	125	92	190	140	240	175	275	200	350	255	320	240	400	300
M18	135	100	175	125	260	195	330	250	375	275	475	350	440	325	560	410
M20	190	140	240	180	375	275	475	350	530	400	675	500	625	460	800	580
M22	260	190	330	250	510	375	650	475	725	540	925	675	850	625	1075	800
M24	330	250	425	310	650	475	825	600	925	675	1150	850	1075	800	1350	1000
M27	490	360	625	450	950	700	1200	875	1350	1000	1700	1250	1600	1150	2000	1500
M30	675	490	850	625	1300	950	1650	1200	1850	1350	2300	1700	2150	1600	2700	2000
M33	900	675	1150	850	1750	1300	2200	1650	2500	1850	3150	2350	2900	2150	3700	2750
M36	1150	850	1450	1075	2250	1650	2850	2100	3200	2350	4050	3000	3750	2750	4750	3500

DO NOT use these values if a different torque value or tightening procedure is given for a specific application. Torque values listed are for general use only. Check tightness of fasteners periodically.

Shear bolts are designed to fail under predetermined loads. Always replace shear bolts with identical property class.

Fasteners should be replaced with the same or higher property class. If higher property class fasteners are used, these should only be tightened to the strength of the original.

Make sure fasteners threads are clean and that you

properly start thread engagement. This will prevent them from failing when tightening.

Tighten plastic insert or crimped steel-type lock nuts to approximately 50 percent of the dry torque shown in the chart, applied to the nut, not to the bolt head. Tighten toothed or serrated-type lock nuts to the full torque value.

a "Lubricated" means coated with a lubricant such as engine oil, or fasteners with phosphate and oil coatings. "Dry" means plain or zinc plated without any lubrication.

Index

Aerosol Grease7-2
Bale Sizes1-3
Before Operation2-1
BWC - Channel 1 - Current/Target Wraps Display.6-2
BWC - Channel 2 - Store Totals6-3
BWC - Channel 3 – Part Total6-4
BWC - Channel 4 - Grand Total6-5
BWC - Channel 5 - Bale Wrapping Rate.6-5
BWC - Channel 6 - Bale Wrapping Speed6-5
BWC - Control Switches6-1
BWC - Display a Store Total.6-3
BWC - Display Bale Wrapping Rate6-5
BWC - Display Bale Wrapping Speed6-5
BWC - Display Grand Total.6-5
BWC - Display Part Total6-4
BWC - Early Warning Alarm6-3
BWC - Introduction6-1
BWC - Manually reset Current No. of Wraps to Zero6-2
BWC - Program the Overspeed Alarm6-6
BWC - Program the Target Wraps6-2
BWC - Reset a Store Total6-4
BWC - Reset Part Total6-4
BWC - Reset Timing Period6-5
BWC - Select a Store Total6-4
BWC - Total Reset6-6
Continuous Wrapping5-6
Decal Locations2-2
Dimensions1-1
Electrical Connection3-3
First Bale Wrapping5-5
Grease Gun7-1
Guide Roller Adjustment4-2
Loading Bales5-4
Miter Gear Replacement4-1
Operator's Manual	II
Orientation1-2
Plastic Wrap Requirements.5-4
Roller Chain Adjustment4-2
Safety Decals2-4
Safety Guidelines.2-1
Section 1: General Information1-1
Section 2: Safety2-1
Section 3: Initial Setup3-1
Section 4: Adjustments and Repairs4-1

Section 5: Operating Procedure5-1
Section 6: Bale Wrap Computer (BWC)6-1
Section 7: Grease Points7-1
Serial Number Plate	II
Specifications1-3
Storage & Maintenance2-1
Suitable Wrapping Timeframe1-3
Tensioner Adjustment4-1
Terminology1-2
To Install Plastic Wrap Film5-2
Torque Values - Imperial	IV
Torque Values - Metric	V
Tractor Hookup5-1
Transportation5-6
Trouble Shooting Plastic Installation5-3
Unloading5-5
Warranty and Limitation of Liability	II
Wrap Operation Setup5-1



Scan with smartphone to
download latest manual.



WARNING

The paint used on this product contains chemicals known in the state of California to cause cancer, birth defects, or other reproductive harm.

TUBE•LINE™